

**MODEL WSP-i350**

**(3inch Industrial Printer)**



**WOOSIM SYSTEMS Inc.**

**#501, Daerung Technotown 3th,  
448, Gasan-Dong, GeumChun-Ku,  
Seoul, Korea**

**Tel : +82-2-2107-3700**

**Fax : +82-2-2107-3707**

**URL: <http://www.woosim.com>**

## **Copyright**

**WSP-i350** 3inch Industrial printer operator's manual.

Copyright 2008 by Woosim Systems Inc.

All rights reserved.

The information contained in this manual is the property of Woosim Systems Inc. and may not be reproduced in whole or in part without the prior written permission of Woosim Systems Inc.

## **Trademark**



a registered trademark of Woosim Systems Inc.

All other trademark are the properties of their respective companies.

## **Caution**

Some semiconductor devices are easily damaged by static electricity. You should turn the printer "OFF", before you connect or removed the cable on the rear side, in order to guard the printer against the static electricity.

If the printer is damaged by the static electricity, you should turn the printer "OFF"

## ■ Introduction

The **WSP-i350** is the ideal solution for Mobile banking system , Retail, point of sales, Credit card Transaction, other traveling and mobile computing etc.

The general features of WSP-i350 printer are as follows:

- ▶ Pocket size (120 × 130.5 × 58.3mm)
- ▶ Light weight(520g) for true mobility
- ▶ Very silent printing thru direct thermal printing method
- ▶ High speed (60mm/sec, MAX)
- ▶ UART(RS-232C or TTL), IrDA Ver1.1, Bluetooth Ver2.0 interface
- ▶ Support Magnetic Stripe Reader
- ▶ Support Graphic LCD(128 × 32dots) with Blue LED Backlight
- ▶ Support text and graphic printing
- ▶ Support bit-image(logo), firmware download
- ▶ Easier paper roll loading by CLAMSHELL design
- ▶ One touch paper cover
- ▶ Printer door open & Paper-out sensor
- ▶ Microsoft Windows 98/ME/XP/2000 compatible.
- ▶ In field programming – Update Firmware, Download Fonts and Logos
- ▶ Support bit-image(logo) download.
- ▶ Flow control : Software (XON/XOFF)
  - ※ Hardware flow control not supported in printer.

## **▣ Operating Precautions**

Please follow the precautions below to enjoy and maintain the full performance of the printer.

### **▶ Using the Printer**

- Be careful not to drop or bump the printer on a hard surface.
- Do not install the printer in direct sunlight or such areas.  
Suitable environment for the use of the printer is as follows:
  - ◆ Operating temperature :-10°C to 50°C
  - ◆ Relative humidity : 10% to 90% (No condensation)
- Do not install the printer near devices that generate strong electromagnetic fields such as a copy machine.
- Do not open the platen cover during printing .
- Do not remove or reinstall the communication cable during printing or transmission.
- Do not touch the connectors of the communication during printing.
- Switch the POWER OFF when not in use.
- Do not use alcohol or other solvent.
- The AC adapter, the battery charger and the battery pack may become warm when in use. This is normal and is not a malfunction.
- When the battery pack is used at low temperature, the length of time the printer can be used may be shortened.

### **▶ Thermal Paper Handling**

- Store the thermal paper in a cool, dry and dark place.
- Do not rub the paper with hard object.
- Do not leave the paper with hard object.
- Do not allow plastic film, erasers, or adhesive tape to touch the paper for long periods.
- Do not stack the thermal paper with diazo copies immediately after copying or wet-type copies.
- Do not use chemical glue.
- Always use the clean thermal paper.

# CONTENTS

<b>1. Outline.....</b>	<b>7</b>
1.1. Model classifications.....	7
1.2. Product Part Number System.....	7
1.3. Specifications.....	8
<b>2. Setting up the printer.....</b>	<b>9</b>
2.1. Printer & Accessories.....	9
2.2. Printer Features.....	10
2.3. Replacing paper roll.....	12
2.4. Power supply.....	13
2.4.1. Specified power supply.....	13
2.4.2. Installing the battery and the belt strap.....	13
2.4.3. Recharging the battery pack.....	14
2.5. Set operation mode.....	15
<b>3. Interface.....</b>	<b>18</b>
3.1. UART(RS-232C or TTL).....	18
3.2. Infrared data communication.....	19
3.3. Bluetooth.....	20
<b>5. Using the printer.....</b>	<b>21</b>
5.1. Control panel.....	21
5.2. The self test.....	22
<b>6. Consumable Parts.....</b>	<b>23</b>
6.1. Recommended paper.....	23
6.2. Printing position.....	23
<b>7. Print Control Function.....</b>	<b>24</b>
7.1. Print Command.....	26
7.2. Line Spacing Command.....	28
7.3. Character Commands.....	29
7.4. Panel Button Commands.....	36
7.5. Print Position Commands.....	37

7.6. Bit-Image Commands.....	50
7.7. Barcode Commands.....	55
7.8. Macro Function Commands.....	61
7.9. Miscellaneous function commands.....	63
7.10. Line & box commands.....	66
7.11. Black mark detection commands.....	67
7.12. Magnetic Card Reader Commands. (optional).....	68
<b>8. Introduction of Protocol IrDA (or Bluetooth) .....</b>	<b>71</b>
8.1. Frame Structure.....	71
8.2. Process of Getting the Printer Status.....	72
8.2.1. Frame Format.....	72
8.3. Process of Printing Data.....	73
8.3.1. Format of Print Data Frame.....	74
8.3.2. Format of ENQ Frame.....	74
8.3.3. Format of ACK Frame.....	75
8.3.4. Format of NACK Frame.....	75
8.3.5. Format of ETX Frame.....	75
8.3.6. Format of EOT Frame.....	75
<b>Appendix .....</b>	<b>76</b>

# 1. Outline.

## 1.1. Model classifications.

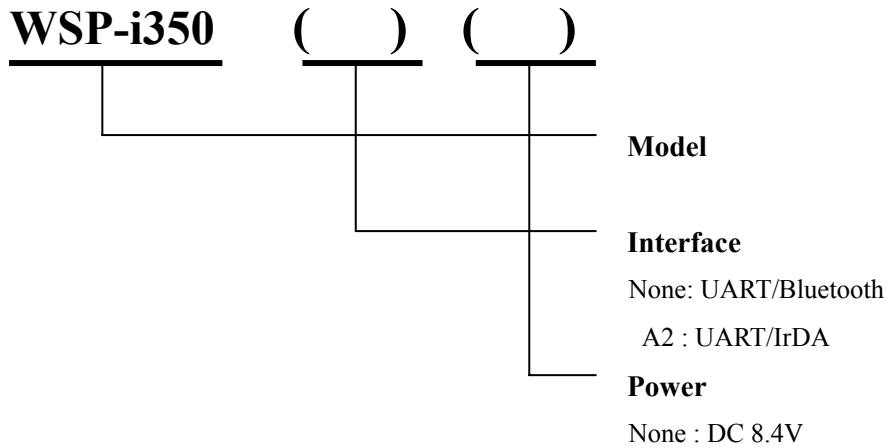

## 1.2. Product Part Number System.

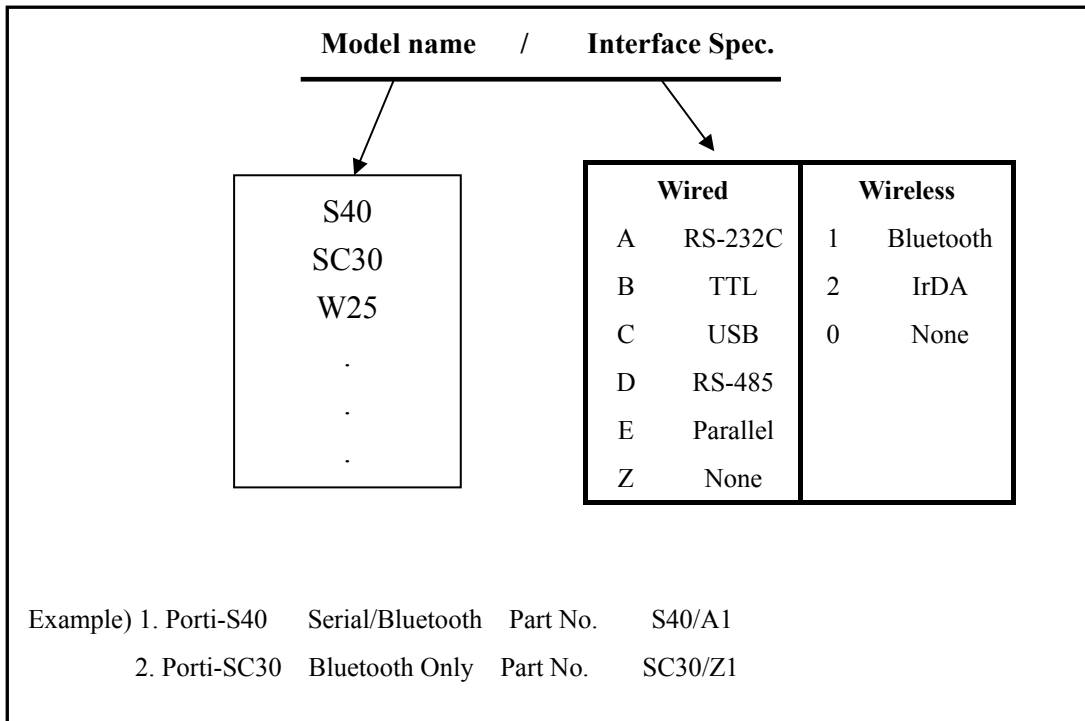

### 1.3. Specifications.

Item	Specifications	
<b>Print method</b>	Direct thermal line printing	
<b>Characters per line</b>	64cpl (MAX)	
<b>Character size</b>	Eng. : 9×24dots, 12×24dots    Kor. : 16×24dots, [24×24dots]	
<b>Optional Characters</b>	Simplified/Traditional Chinese, Arabic, Cyrillic, Russian, Turkish, Greek, Japanese, Persian, Latin9 and Others upon request.	
<b>Resolution</b>	203dpi, 8dots/mm	
<b>Print width</b>	3-inch (72mm, 576dots)	
<b>Print speed</b>	60mm / sec (MAX)	
<b>Dimension</b>	120×130.5×58.3 mm	
<b>Weight</b>	520g (Including battery & roll paper)	
<b>Interface</b>	UART(RS-232C or TTL), IrDA Ver1.1, Bluetooth Ver 2.0	
<b>Paper roll</b>	Thermal roll paper (80mm wide, 50ø)	
<b>Barcodes</b>	1-dimension : Code128, EAN 128, Code39, I2/5, Code93 UPC, EAN, KAN, JAN, CODABAR 2-dimension : PDF417, QR Code, DATA Matrix	
<b>H/W Spec.</b>	MCU : 32bits RISC, FLASH : 4Mbytes, RAM : 8Mbytes	
<b>Receive buffer size</b>	1M bytes	
<b>MSR</b>	ISO 7810 / 7811 / 7812 1&2 or 2&3 Track Reading	
<b>LCD</b>	128 × 32 Dots FSTN (Blue LED Backlight)	
<b>Battery</b>	Rechargeable 7.4V DC/ 1,900mAh (Li-ion)	
<b>Battery duration</b>	1 hour continuous printing	
<b>Battery charger</b>	Input (100~250V AC, 50~60Hz) Output(8.4VDC/0.8A), 4hours full charge time	
<b>Environment conditions</b>	Temperature	-10°C ~ 50°C (operating) -20°C ~ 60°C (storage)
	Humidity	30% - 80% (operating) 10% - 90% (storage)
<b>MCBF(Mean Cycle Between Failure)</b>	Mechanical	37,000,000 lines
	Head	Approximately 50 Km

## 2. Setting up the printer.

### 2.1. Printer & Accessories

Your printer box should include these items. If any items are damaged or missing, please contact your dealer for assistance.



**WSP-i350**



**Battery Pack**

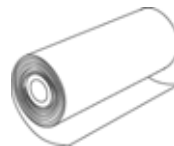

**Paper Roll**



**Battery Charger**

#### OPTIONAL



**Communication Cable**



**Shoulder band**



**MSR**

## 2.2. Printer Features

### Part Name

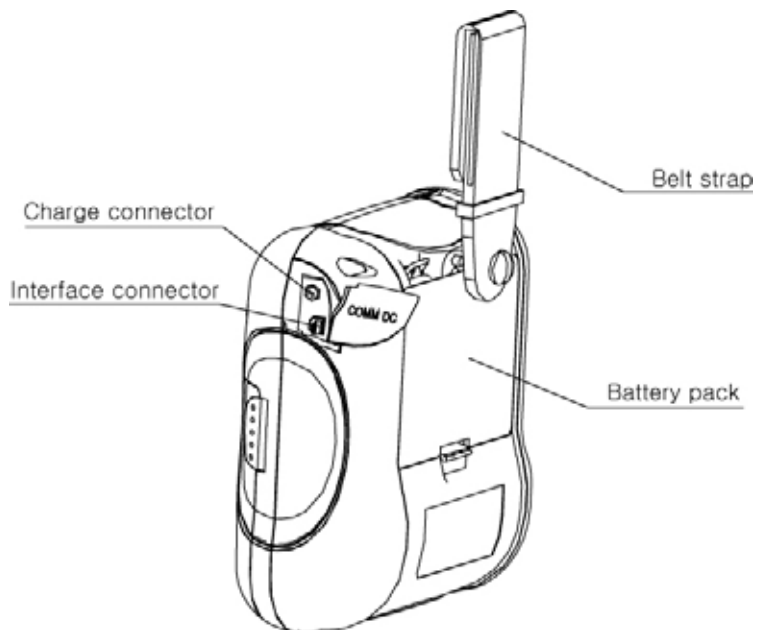
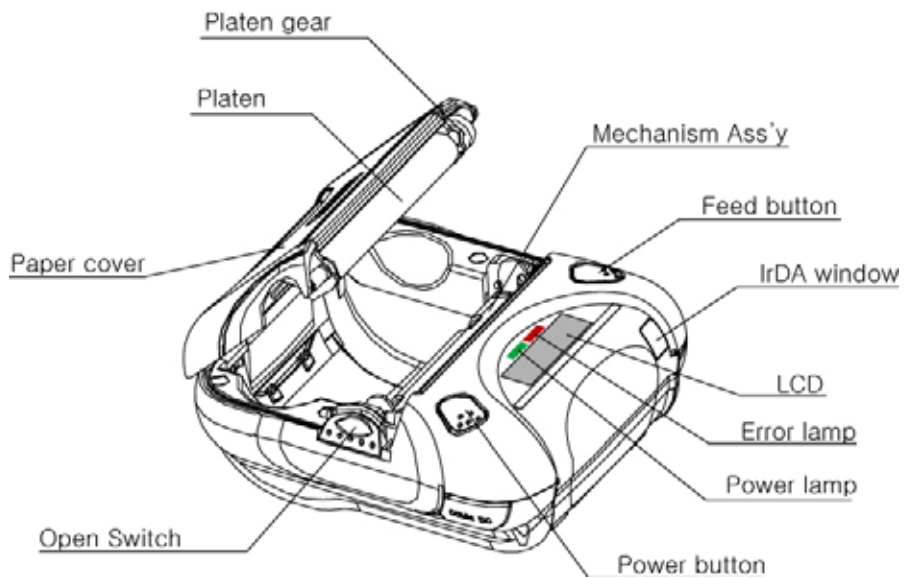

## Dimensions

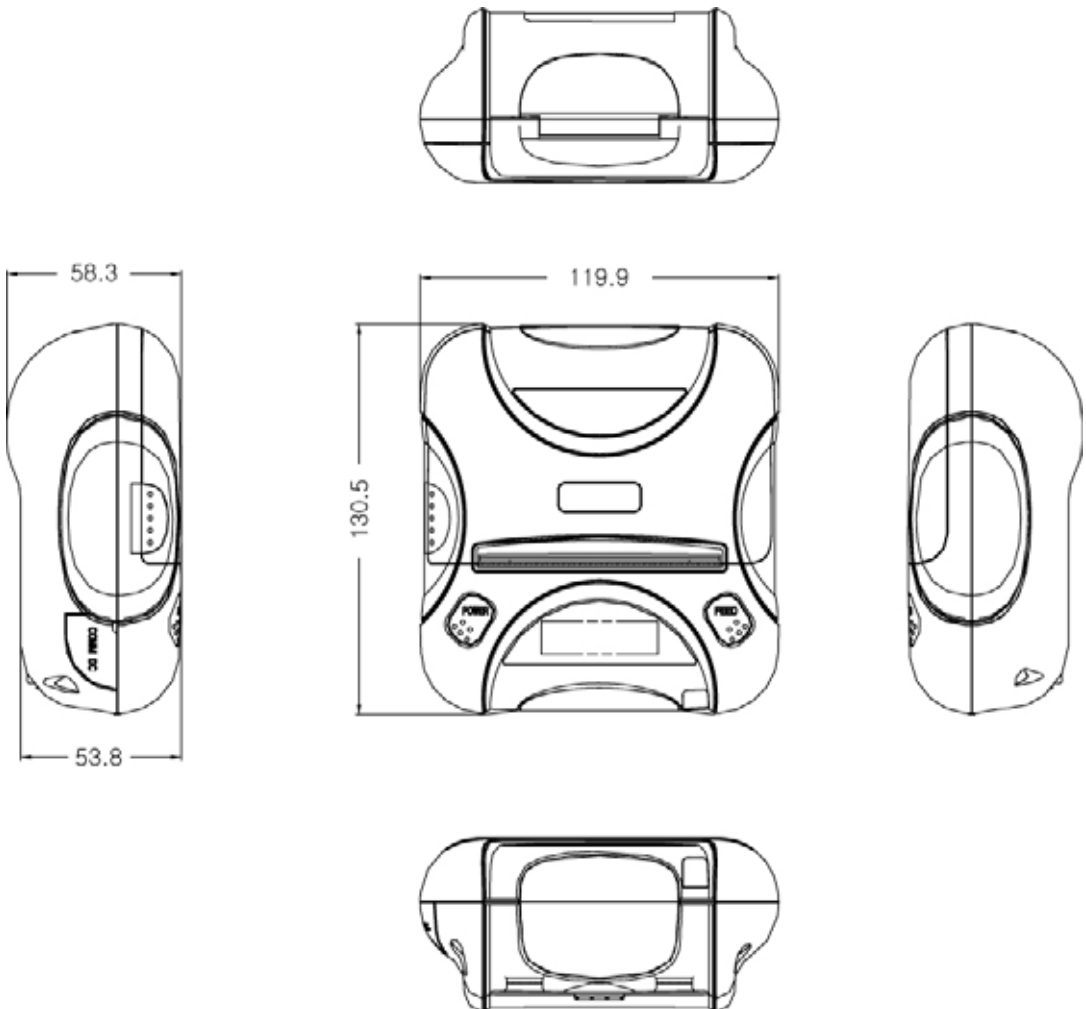

## 2.3. Replacing paper roll.

**Note :** Be sure to use paper rolls that meet the specifications.  
Do not use paper rolls that have the paper glued to the core because the printer cannot detect the paper end correctly.

1. Make sure that the printer is not receiving data; otherwise, data may be lost.
2. Open the paper cover by placing your fingers under the paper cover lock and pull a paper cover lock open.

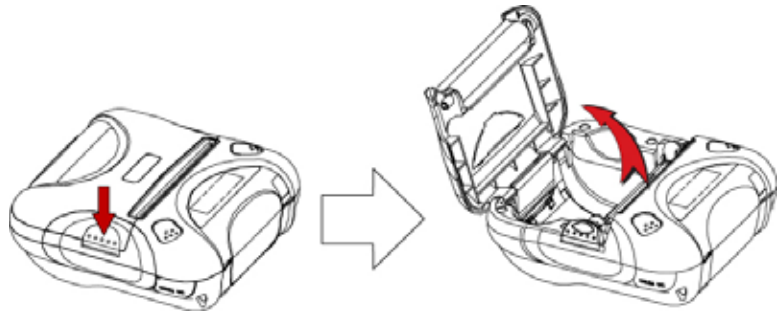

3. Insert a new paper roll as shown.

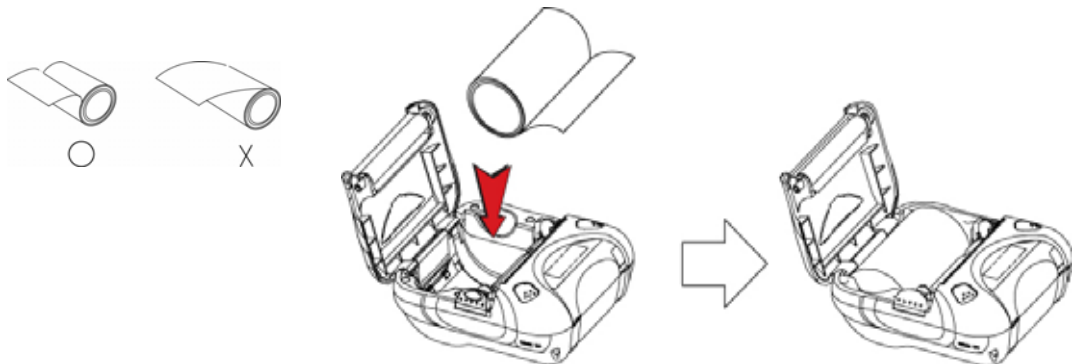

4. Tear the excess paper off using the edge of paper door as a tear bar.

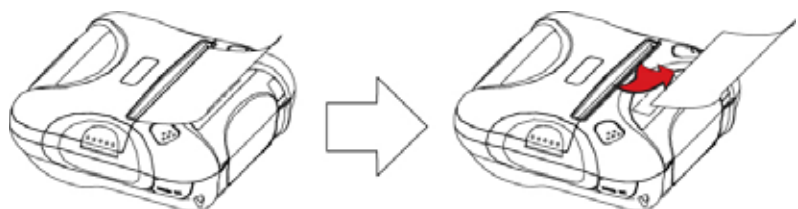

## 2.4. Power supply

### 2.4.1. Specified power supply.

The following specification is requested for Power supply.

Battery Charger : DC 8.4V/0.8A

Avoid using power supply which its power capacity of power current is extremely high.

### 2.4.2. Installing the battery and the belt strap

**NOTE :**

- Before installing or removing the battery pack, ensure the printer is **OFF**.
- If the printer is not used for long period of time, remove the battery pack from the printer.

#### \*\* BATTERY\*\*

To install battery pack, proceed as follows:

- Insert the Battery pack in the direction of the arrow.

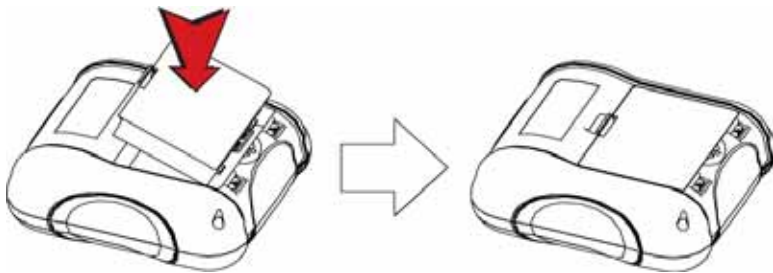

Reverse the order to remove the battery pack.

#### \*\* BELT STRAP\*\*

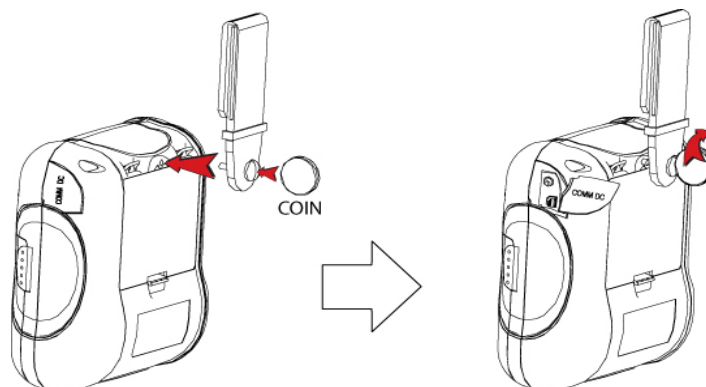

### 2.4.3. Recharging the battery pack

For recharging the battery pack, install the battery pack in the printer.  
Insert the Battery Charger to the charge connector of the printer.

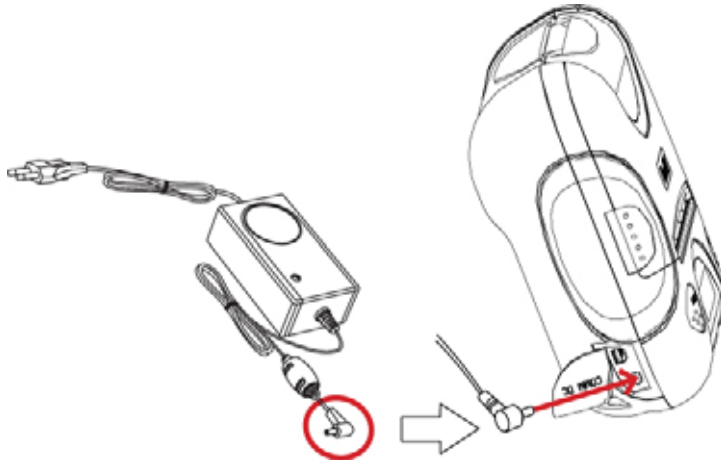

- NOTE :**
- While charging the printer, turn off the printer power.
  - Do not remove the battery during charging.
  - The battery is consumable parts and when purchasing, compared to the use hour is gradually decreases. (Warranty 6 month)
  - If the printer is not used for a long time, unplug the power cord from the printer and outlet.
  - The recharging time depends on the voltage level and ambient temperature of the battery. Normally, it takes about 4 to 5 hours to recharge a battery pack.
  - You must use only the supplied adapter.
  - Red Lamp : charging the battery.  
Green Lamp: charging is finished.

## 2.5. Set operation mode.

1. Change the mode and option using the mode Code (Table1).

- **POWER button** : changing Printer MODE status.

- **FEED button** : changing OPTION status.

2. [Example] The defaults of the printer are :

UART/ 9600 BPS/8 DATA BIT/ NO Parity/1 STOP BIT/ Density LOW

If a user wants to modify the defaults with

Bluetooth/38400 BPS/7 DATA BIT/Even Parity/2 STOP BIT/Density HIGH

▶ After pressing the POWER and the FEED button simultaneously, if the ERROR lamp 5 turn signals POWER button is converted with MODE functions

→ You will see present **COMMUNICATION** mode in the LCD.

→ Press the **POWER Button** two times.

(The interface mode has set to Bluetooth mode.)

▶ Press **FEED button** one time.

→ You will see present **BAUD RATE** mode in the LCD.

→ Press **POWER Button** 2 times.

(The baud rate has set to 38,400 bps)

▶ Press **FEED button** one time.

→ You will see present **DATA BIT** mode in the LCD.

→ Press **POWER Button** one time.

(The data bit has set to 7 data bit.)

▶ Press **FEED button** one time.

→ You will see present **PARITY BIT** mode in the LCD.

→ Press **POWER Button** 2 times.

(The parity bit has set to even parity bit.)

- ▶ Press **FEED button** one time.
  - You will see present **STOP BIT** mode in the LCD.
  - Press **POWER Button** one time.  
(The stop bit has set to 2 stop bit.)

- ▶ Press **FEED button** one time.
  - You will see present **DENSITY** mode in the LCD.
  - Press **POWER Button** two times.  
(The density has set to high.)

If all the mode have set, press the **FEED Button** and the **POWER Button** at the same time after then release the buttons at the same time.

The printer will print out the mode status which has modified.

**(Bluetooth/38,400 BPS/ 7 DATA BIT/Even Parity/ 2 STOP BIT / Density HIGH)**

If the status is not correct, please try it again according to the procedure.

<b>MODE</b>	<b>POWER Lamp (Green)</b>	<b>ERROR Lamp (Red)</b>	<b>Option</b>
<b>Communication Port</b>	1	1	UART
		2	Protocol UART
		3	Raw IrDA (or Bluetooth)
		4	Protocol IrDA (or Protocol Bluetooth)
<b>Baud Rate</b>	2	1	9600 bps
		2	19200 bps
		3	38400 bps
		4	57600 bps
		5	115200 bps
<b>Data Bit</b>	3	1	7 Data bit
		2	8 Data bit
<b>Parity Bit</b>	4	1	No Parity
		2	Even Parity
		3	Odd Parity
<b>Stop Bit</b>	5	1	1 Stop bit
		2	2 Stop bit
<b>Density</b>	6	1	Density Low
		2	Density Medium
		3	Density High
<b>Mark</b>	7	1	No use
		2	Use
<b>Sensor</b>	8	1	Low
		2	Medium1
		3	Medium2
		4	High

### 3. Interface.

#### 3.1. UART(RS-232C or TTL)

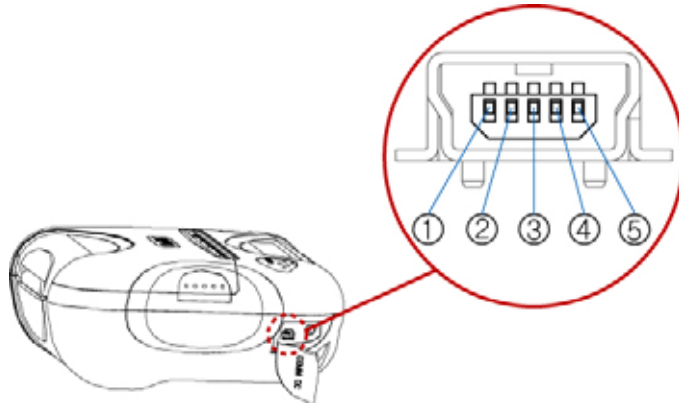

Pin No.	Name	Direction	Function
1	TxD	Output	Transmit Data
2	RxD	Input	Receive Data
3	CTS	-	-
4	NC.	-	-
5	GND	-	Ground

The WSP-i350 printer has a RS-232C or TTL interface and is connected by means of a 5 pin mini USB socket. In the following table, the signals present on the Mini-USB socket are listed:

**NOTE :** ● When data receiving, when it removes the communication cable, it loses a data.

### 3.2. Infrared data communication

The WSP-i350 has a serial interface for bi-directional data exchange.

The infrared port is the right side of the front part.



1. To use the WSP-i350's infrared port by a Computer or a Personal Digital Assistant (PDA) with IR port is required.
2. Position a PDA conforming to the specifications in point not more than 50 centimeter away from the printer's infrared port. Make sure the two ports are in front of each other with an angle of not more than 15° on the four sides.

**NOTE :** ● When infrared ray communication doing, directness it does not see the IrDA window roll up.  
Eye damage there is a danger.

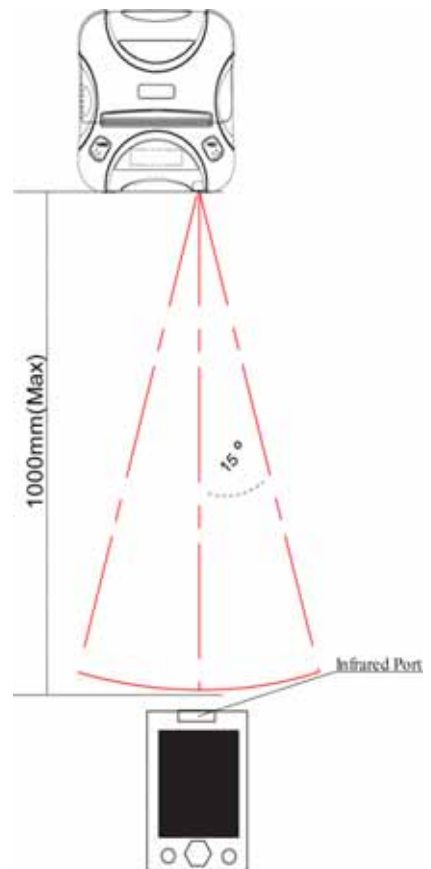

### 3.3. Bluetooth

Category	Specification
Bluetooth Spec.	Bluetooth V2.0/ Class2 (10m)
Frequency Range	2.4GHz ISM BAND
Data Transmission Rate	57600bps Fixed.
Data bit	8 Data bit Fixed.
Parity bit	No parity Fixed.
Stop bit	1 Stop bit Fixed.

#### Notice

If the quantity of data which is printed at once is more than 10K byte on Bluetooth communication, it would cause the buffer to overflow and the data to get damaged.

## 5. Using the printer.

### 5.1. Control panel.

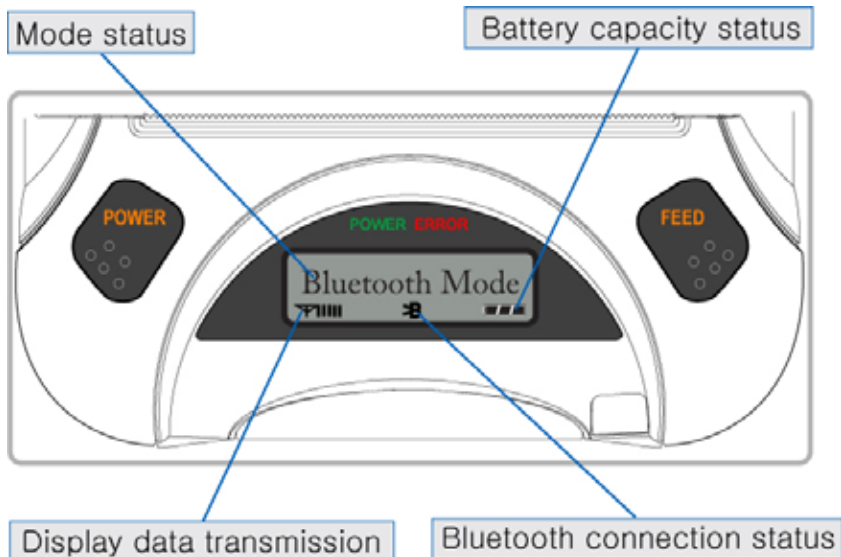

#### ► Button

##### - FEED Button :

When the printer is on, paper can be feed manually by pressing and holding the FEED button for more than one second.

##### - POWER Button :

When of 5 or more seconds presses and power comes to on or off.

After pressing the POWER and the FEED button simultaneously, if the ERROR lamp 5 turn signals POWER button is converted with MODE functions.

MODE functions are for use to change communication mode.

(Refer to **2.5. Set operation mode** for details about mode conversion)

#### ► Panel lamp

-POWER (Green) : Printer is ON and ready to receive data.

-ERROR (Red) : Indicated a fault condition or a printer error.  
(i.e : no paper, paper cover opened. etc.)

## **5.2. The self test.**

The self test procedure will check most of the printer functions.

For self test, turn on the power while holding down the FEED Button.

The Self-Test checks the following :

- 1) Make sure paper roll has been installed properly.
- 2) The Self-Test prints the current printer status, which provides the control ROM version and the communication method setting.
- 3) After printing the current printer status, Self-Test will print a pattern using the built-in character set.
- 4) The Self-Test automatically ends.

The printer is ready to receive data as soon as it completed the self test.

## 6. Consumable Parts.

### 6.1. Recommended paper.

Type	: Thermal Paper
Paper width	: 80mm
Paper thickness	: $60 \pm 5 \mu\text{m}$
Outer diameter	: $\text{Ø}50\text{mm}$ or less
Recording side	: Outside of roll



#### Cautions

1. Do not paste the paper to the core. And the roll paper which has Near end mark printing on its near end is recommended.
2. Chemicals or oil may change the color of paper, or printed Characters may fade.
3. Change of paper color starts from approx 70 .  
Pay attention to heat, humidity and sun light.
4. Color of paper may be changed by being scratched by nail or hard metal, etc

### 6.2. Printing position.

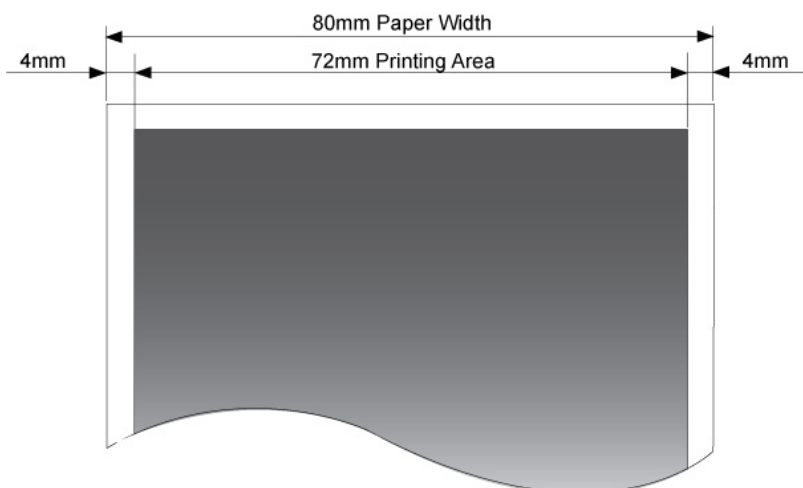

## 7. Print Control Function.

### • Supported Commands List

Command	Name	Function Type	Page
<b>HT</b>	Horizontal tab	Print position	40
<b>LF</b>	Print and line feed	Print	26
<b>FF</b>	Print and return to standard mode	Print	27
<b>CAN</b>	Cancel print data in page mode	Miscellaneous function	65
<b>ESC FF</b>	Print data in page mode	Print	27
<b>ESC SP</b>	Set right-side character spacing	Character	30
<b>ESC !</b>	Select print mode	Character	31
<b>ESC \$</b>	Set absolute print position	Print position	37
<b>ESC *</b>	Select bit-image mode	Bit image	50
<b>ESC -</b>	Turn underline mode on/off	Character	32
<b>ESC 2</b>	Select default line spacing	Line spacing	28
<b>ESC 3</b>	Set line spacing	Line spacing	28
<b>ESC @</b>	Initialize printer	Miscellaneous function	63
<b>ESC D</b>	Set horizontal tab positions	Print position	41
<b>ESC E</b>	Turn emphasized mode on/off	Character	33
<b>ESC J</b>	Print and feed paper	Print	26
<b>ESC L</b>	Select page mode	Miscellaneous function	63
<b>ESC O</b>	Set print starting position.	Print position	49
<b>ESC P</b>	Set the movement position from the black mark	Black mark detection	67
<b>ESC R</b>	Select an international character set	Character	30
<b>ESC S</b>	Select standard mode	Miscellaneous function	64
<b>ESC T</b>	Select print direction in page mode	Print position	46
<b>ESC W</b>	Set printing area in page mode	Print position	44
<b>ESC X 4</b>	Define user-defined bit-image	Bit image	53
<b>ESC \</b>	Set relative print position	Print position	38

<b>Command</b>	<b>Name</b>	<b>Function Type</b>	<b>Page</b>
<b>ESC Z</b>	Print 2D barcode	Barcode	59
<b>ESC \</b>	Set relative print position	Print position	38
<b>ESC a</b>	Select justification	Print position	39
<b>ESC c 5</b>	Enable/disable panel buttons	Panel button	36
<b>ESC d</b>	Print and feed n lines	Print	27
<b>ESC z</b>	Feed the paper to the black mark position	Black mark detection	67
<b>ESC y</b>	Feed the paper to the movement position		
<b>ESC {</b>	Turn upside-down printing mode on/off	Character	33
<b>ESC v</b>	Transmit paper sensor status	Status	54
<b>ESC M</b>	Set Magnetic Card Reader mode	Magnetic card reader	67
<b>EOT</b>	Exit Magnetic Card Reader & Smart Card Reader mode	Exit card reader	69
<b>GS !</b>	Select characters size	Character	34
<b>GS \$</b>	Set absolute vertical print position in page mode	Print position	47
<b>GS :</b>	Start/end macro definition	Macro function	61
<b>GS B</b>	Turn white/black reverse printing mode On/off	Character	35
<b>GS H</b>	Select printing position of HRI characters	Barcode	58
<b>GS L</b>	Set left margin	Print position	42
<b>GS W</b>	Set printing area width	Print position	43
<b>GS \</b>	Set relative vertical print position in page mode	Print position	48
<b>GS Z</b>	Select 2D Barcode	Barcode	59
<b>GS i</b>	Print box & line in page mode	Box & line command	66
<b>GS \</b>	Set relative vertical print position in page mode	Print position	48
<b>GS ^</b>	Execute macro	Macro function	62
<b>GS h</b>	Set barcode height	Barcode	55
<b>GS k</b>	Print bar code	Barcode	56
<b>GS w</b>	Set barcode width	Barcode	55

## 7.1. Print Command.

The WSP-i350 supports the following commands for printing character and advancing paper:

<b>Command</b>	<b>Name</b>
<b>LF</b>	Print and line feed
<b>ESC J</b>	Print and feed paper
<b>ESC d</b>	Print and feed <b>n</b> lines
<b>FF</b>	Print and return to standard mode (in page mode)
<b>ESC FF</b>	Print data in page mode

### **LF**

[Name]	Print and line feed
[Format]	ASCII LF HEX 0A Decimal 10
[Description]	Print the data in the print buffer and feeds one line based on the current line spacing.
[Note]	This command sets the print position to the beginning of the line.
[Reference]	<b>ESC 2, ESC 3</b>

### **ESC J n**

[Name]	Print and feed paper.
[Format]	ASCII ESC J n HEX 1B 4A n Decimal 27 74 n
[Range]	$0 \leq n \leq 255$
[Description]	Prints the data in the print buffer and feeds the paper [ <b>n</b> * (vertical or horizontal motion unit)] inches.

## **ESC d n**

[Name]	Print and feed n lines
[Format]	ASCII    ESC    d        n HEX    1B    64        n Decimal 27    100      n
[Range]	$0 \leq n \leq 255$
[Description]	Prints the data in the print buffer and feeds n lines.
[Note]	1) This command sets the print starting position to the beginning of the line. 2) This command does not affect the line spacing set by ESC 2 or ESC 3.
[Reference]	<b>ESC 2, ESC 3</b>

## **FF**

[Name]	Print and return to standard mode in page mode.
[Format]	ASCII    FF HEX    0C Decimal 12
[Description]	Prints the data in the print buffer collectively and returns to standard mode.
[Note]	1) The buffer data is deleted after being printed. 2) The Printing area set by ESC W is reset to the default setting. 3) This command sets the print position to the beginning of the line. 4) This command is enabled only in page mode.
[Reference]	<b>ESC FF, ESC L, ESC S</b>

## **ESC FF**

[Name]	Print data in page mode.
[Format]	ASCII    ESC    FF HEX    1B    0C Decimal 27    12
[Description]	In page mode, prints all buffered data in the printing area collectively.
[Note]	This commands is enabled only in page mode. After printing the printer does not clear the buffered data, setting values for ESC T and ESC W, and the position for buffering.
[Reference]	<b>FF, ESC L, ESC S</b>

## 7.2. Line Spacing Command.

The **WSP-i350** supports the following commands for setting line spacing.

These commands only set the line spacing; they do not actually advance the paper.

The line spacing set using these commands affects the results of **LF** and **ESC d** and paper feeding by using the FEED button.

<b>Command</b>	<b>Name</b>
<b>ESC 2</b>	Select default line spacing
<b>ESC 3</b>	Set line spacing

### **ESC 2**

[Name]	Select default line spacing
[Format]	ASCII    ESC    2
	HEX     1B     32
	Decimal 27     50
[Description]	Selects 1/7 inch line (approximately 3.75mm) spacing.
[Note]	The line spacing can be set independently in standard mode and in page mode.
[Reference]	<b>ESC 3</b>

### **ESC 3 n**

[Name]	Set line spacing
[Format]	ASCII    ESC    3     n
	HEX     1B     33     n
	Decimal 27     51     n
[Range]	$0 \leq n \leq 255$
[Description]	Sets the line spacing to [n * vertical or horizontal motion until] inches.
[Note]	1) The line spacing can be set independently in standard mode and in page mode. 2) The horizontal and vertical motion unit are specified by GS P. Changing the horizontal or vertical motion unit does not affect the current line spacing.

3) The GS P command can change the horizontal (and vertical) motion unit. However, the value cannot be less than the minimum vertical movement amount, and it must be in even units of the minimum vertical movement amount.

4) In standard mode, the vertical motion unit (y) is used.

5) In page mode, this command functions as follows, depending on the starting position of the printable area:

When the starting position is set to the upper left or lower right of the printable area using ESC T, the vertical motion unit(y) is used.

When the starting position is set to the upper right or lower left of the printable area using ESC T, the horizontal motion unit(x) is used.

[Reference]      **ESC 2, GS P**

### **7.3. Character Commands.**

The **WSP-i350** supports the following commands for setting character font and size:

<b>Command</b>	<b>Name</b>
<b>ESC SP</b>	Set right-side character spacing
<b>ESC R</b>	Select an international character set
<b>ESC !</b>	Select print mode
<b>ESC -</b>	Turn underline mode on/off
<b>ESC E</b>	Turn emphasized mode on/off
<b>ESC G</b>	Turn double-strike mode on/off
<b>ESC {</b>	Turn upside-down
<b>GS !</b>	Select character size
<b>GS B</b>	Turn white/black reverse printing mode on/off

## **ESC SP n**

[Name]	Set right-side character spacing.
[Format]	ASCII    ESC    SP    n HEX    1B    20    n Decimal 27    32    n
[Range]	$0 \leq n \leq 255$
[Description]	Sets the character spacing for the right side of the character to [n * horizontal or vertical motion units] inches.
[Note]	1) The right side character spacing for double-width mode is twice the normal value. When characters are enlarged, the right side character spacing is n times normal value. 2) This command sets values independently in each mode. 3) The horizontal and vertical motion unit are specified by GS P. Changing the horizontal or vertical motion unit does not affect the current right-side spacing. 4) The maximum right side spacing is 255/180 inches, Any setting exceeding the maximum is converted to the maximum automatically.
[Default]	n = 0
[Reference]	<b>GS P</b>

## **ESC R n**

[Name]	Select an international character set.
[Format]	ASCII    ESC    R    n HEX    1B    52    n Decimal 27    82    n
[Range]	$0 \leq n \leq 10$
[Description]	Selects an international character set n from the following table.

n	Character set	n	Character set	n	Character set
0	U.S.A	5	Sweden	10	Denmark II
1	France	6	Italy		
2	Germany	7	Spain		
3	U.K	8	Japan		
4	Denmark I	9	Norway		

[Default]            n = 0

### **ESC ! n**

[Name]            Select print mode.

[Format]        ASCII    ESC    !        n  
                   HEX    1B    21        n  
                   Decimal 27    33        n

[Range]         0 ≤ n ≤ 255

[Description]    Select print mode(s) using n as follows.

Bit	Off / On	Hex	Decimal	Function
0	Off	00	0	Character font A (12 x 24)
	On	01	1	Character font B (9 x 24)
1	Off	-	-	Undefined
	On	-	-	Undefined
2	Off	-	-	Undefined
	On	-	-	Undefined
3	Off	00	0	Emphasized mode not selected
	On	08	8	Emphasized mode selected
4	Off	00	0	Double-height mode not selected
	On	10	16	Double-height mode selected
5	Off	00	0	Double-width mode not selected
	On	20	32	Double-width mode selected
6	Off	-	-	Undefined
	On	-	-	Undefined
7	Off	00	0	Underline mode not selected
	On	80	128	Underline mode selected

- [Note]
- 1) When both double-height and double-width modes are selected, quadruple size characters are printed.
  - 2) The printer can underline all characters, but can not underline the space set by **HT**.
  - 3) The thickness of the underline is that selected by ESC -, regardless of the character size.
  - 4) When some characters in a line are double or mode height, all the characters on the line are aligned at the baseline.
  - 5) ESC - can also turn on or off underline mode. However, the setting of the last received command is effective.
  - 7) GS ! can also select character size. However, the setting of the last received command is effective.

[Reference] **ESC -, ESC E, GS!**

### **ESC - n**

[Name]	Turn underline mode on/off
[Format]	ASCII    ESC    -        n HEX     1B     2D       n Decimal 27     45       n
[Range]	$0 \leq n \leq 2$
[Description]	Turns underline mode on or off, based on the following values of n;

n	Function
<b>0, 48</b>	Turns off underline mode
<b>1, 49</b>	Turns on underline mode (1 dot thick).
<b>2, 50</b>	Turns on underline mode (2 dot thick)

- [Notes]
- 1) The printer can underline all characters (including right-side character spacing), but cannot underline the space set by HT.
  - 2) The printer cannot underline white/black inverted characters.
  - 3) When underline mode is turned off by setting the value of n to 0 or 48, the following data is not underlined, and the underline thickness set before the mode is turned off does not change.

The default underline thickness is 1 dot.

4) Changing the character size does not affect the current underline thickness.

5) Underline mode can also be turned on or off by using ESC !.

Note, however, that the last received command is effective.

[Default] n = 0

[Reference] **ESC !**

### **ESC E n**

[Name] Turn emphasized mode On/Off.

[Format] ASCII ESC E n  
HEX 1B 45 n  
Decimal 27 69 n

[Range]  $0 \leq n \leq 255$

[Description] Turns emphasized mode on of off.

When the LSB(least significant bit) is 0, emphasized mode is turned off.

When the LSB(least significant bit) is 1, emphasized mode is turned on.

[Note] 1) Only the least significant bit of n is enabled.

2) This command and ESC ! turn on and off emphasized mode in the same way. Be careful when this command is used with ESC !

[Default] n = 0

[Reference] **ESC !**

### **ESC { n**

[Name] Turn On/Off upside-down printing mode

[Format] ASCII ESC { n  
HEX 1B 7B n  
Decimal 27 123 n

[Range]  $0 \leq n \leq 255$

[Description] Turns upside-down printing mode on of off

When the LSB is 0, upside-down mode is turned off.

When the LSB is 1, upside-down mode is turned on.

[Note]

- 1) Only the lowest significant bit of n is valid.
- 2) This command is enabled only when processed at the beginning of a line in standard mode.
- 3) When this command is input in page mode, the printer performs only internal flag operations.
- 4) This command does not affect printing in page mode.
- 5) In upside-down printing mode, the printer rotates the line to be printed by 180 degree and then prints it.

[Default] n = 0

[Example]



### **GS ! n**

[Name] Select character size

[Format] ASCII GS ! n  
HEX 1D 21 n  
Decimal 29 33 n

[Range]  $0 \leq n \leq 255$

[Description] ( $1 \leq$  vertical number of times  $\leq 8$ ,  $1 \leq$  horizontal number of times  $\leq 8$ )  
Selects the character width using bits 0 to 2 and selects the character height using bits 4 to 7, as follows;

Hex	Decimal	Width
00	0	1 (normal)
01	1	2 (double width)
02	2	3
03	3	4
04	4	5
05	5	6
06	6	7
07	7	8

Hex	Decimal	Height
00	0	1 (normal)
10	16	2 (double height)
20	32	3
30	48	4
40	64	5
50	80	6
60	96	7
70	112	8

#### Character Width Selection

#### Character Height Selection

[Notes]

- 1) This command is all characters effective
- 2) If n is outside of the defined range, this command is ignored.
- 3) In standard mode, the vertical direction is the paper feed direction, and the horizontal direction is perpendicular to the paper feed direction.
- 4) In page mode, vertical and horizontal directions are based on the character orientation.
- 5) When characters are enlarged with different sizes on one line, all the characters on the line are aligned at the baseline.
- 6) The ESC ! command can also turn double width and double height modes on or off.

[Default]

n = 0

[Reference]

ESC !

#### GS B n

[Name]

Turn white/black reverse printing mode On/Off.

[Format]

ASCII	GS	B	n
HEX	1D	42	n
Decimal	29	66	n

[Range]

$0 \leq n \leq 255$

[Description]

Turns on or off White/Black reverse printing mode.

- [Notes]
- 1) When the LSB is 0, white/black reverse printing mode is turned on.
  - 2) When the LSB is 1, white/black reverse printing mode is turned off.
  - 3) Only the lowest bit of n is valid.
  - 4) This command is available for built in characters and user defined characters.
  - 5) When white/black reverse printing mode is on, it also applied to character spacing set by ESC SP.
  - 6) This command does not affect the space between lines.
  - 7) White/black reverse mode has a higher priority than underline mode. Even if underline mode is on, it is disabled (but not canceled) when white/black reverse mode is selected.

[Default] n = 0

## 7.4. Panel Button Commands.

The **WSP-i350** supports the following command for enabling and disabling the panel button.

Command	Name
ESC c 5	Enable/disable panel buttons

### **ESC c 5 n**

[Name]	Enable/Disable panel buttons															
[Format]	<table border="1"> <thead> <tr> <th>ASCII</th> <th>ESC</th> <th>c</th> <th>5</th> <th>n</th> </tr> </thead> <tbody> <tr> <td>HEX</td> <td>1B</td> <td>63</td> <td>35</td> <td>n</td> </tr> <tr> <td>Decimal</td> <td>27</td> <td>97</td> <td>53</td> <td>n</td> </tr> </tbody> </table>	ASCII	ESC	c	5	n	HEX	1B	63	35	n	Decimal	27	97	53	n
ASCII	ESC	c	5	n												
HEX	1B	63	35	n												
Decimal	27	97	53	n												
[Range]	$0 \leq n \leq 255$															
[Description]	<p>Enables or disables the panel buttons.</p> <p>When the LSB is 0, the panel buttons are enabled.</p> <p>When the LSB is 1, the panel buttons are disabled.</p>															
[Notes]	1) Only the least significant bit of n is valid.															

- 2) When the panel buttons are disabled, none of them are usable when the Printer cover is closed.
- 3) In this printer, the panel buttons is the FEED button.
- 4) In the macro ready mode, the FEED button are enabled regardless of the settings of this command; however, the paper cannot be fed by using these buttons.

[Default]      n = 0

## 7.5. Print Position Commands.

The **WSP-i350** supports the following commands for setting the print position

<b>Command</b>	<b>Name</b>
<b>ESC \$</b>	Set absolute print position
<b>ESC \</b>	Set relative print position
<b>ESC a</b>	Select justification
<b>HT</b>	Horizontal tab
<b>ESC D</b>	Set horizontal tab positions
<b>GS L</b>	Set left margin
<b>GS W</b>	Set printing area width
<b>ESC W</b>	Set printing area in page mode
<b>ESC T</b>	Select print direction in page mode
<b>GS \$</b>	Set absolute vertical print position in page mode
<b>GS \</b>	Set relative vertical print position in page mode
<b>ESC O</b>	Set print starting position.

### **ESC \$ nL nH**

[Name]	Set absolute print position				
[Format]	ASCII	ESC	\$	nL	nH
	HEX	1B	24	nL	nH
	Decimal	27	36	nL	nH
[Range]	0 ≤ nL ≤ 255				
	0 ≤ nH ≤ 255				

[Description]	Set the distance from the beginning of the line to the position at which subsequent characters are to be printed.
[Notes]	<p>1) The distance from the beginning of the line to the print position is <math>[(nL + nH * 256) * (\text{vertical or horizontal motion unit})]</math> inches.</p> <p>2) Setting outside the specified printable area are ignored.</p> <p>3) The horizontal and vertical motion unit are specified by GS P.</p> <p>4) The GS P command can change the horizontal (and vertical) motion unit. However, the value cannot be less than the minimum horizontal movement amount, and it must be in even units of the minimum horizontal movement amount.</p> <p>5) In standard mode, the horizontal motion unit (x) is used.</p> <p>6) In page mode, horizontal or vertical motion unit differs depending on the starting position of the printable area as follows;</p> <ol style="list-style-type: none"> <li>1. When the starting position is set to the upper left or lower right of the printable area using ESC T, the horizontal motion unit (x) is used.</li> <li>2. When the starting position is set to the upper right or lower left of the printable area using ESC T, the vertical motion unit (y) is used.</li> </ol>
[Reference]	ESC\, GSS, GS\, GS P

### **ESC \ nL nH**

[Name]	Set relative print position															
[Format]	<table border="0"> <tr> <td>ASCII</td> <td>ESC</td> <td>\</td> <td>nL</td> <td>nH</td> </tr> <tr> <td>HEX</td> <td>1B</td> <td>5C</td> <td>nL</td> <td>nH</td> </tr> <tr> <td>Decimal</td> <td>27</td> <td>92</td> <td>nL</td> <td>nH</td> </tr> </table>	ASCII	ESC	\	nL	nH	HEX	1B	5C	nL	nH	Decimal	27	92	nL	nH
ASCII	ESC	\	nL	nH												
HEX	1B	5C	nL	nH												
Decimal	27	92	nL	nH												
[Range]	$0 \leq nL \leq 255,$ $0 \leq nH \leq 255$															
[Description]	Set the print starting position based on the current position by using															
[Notes]	<p>1) This command sets the distance from the current position to <math>[(nL + nH * 256) * \text{horizontal or vertical motion unit}]</math></p>															

2) Any setting that exceeds the printable area is ignored

3) When pitch N is specified to the right;  $nL + nH * 256 = N$

When pitch N is specified to the left (the negative direction), use the complement of 65536.

4) The print starting position moves from the current position to [N \* horizontal or vertical motion unit]

5) The horizontal and vertical motion unit are specified by GS P.

6) The GS P command can change the horizontal (and vertical) motion unit.

However, the value cannot be less than the minimum horizontal movement amount, and it must be in even units of the minimum horizontal movement amount.

7) In standard mode, the horizontal motion unit is used.

8) In page mode, the horizontal or vertical unit differs as follows, depending on the starting point of the printing area;

When the starting position is set to the upper left or lower right of the printable area using ESC T, the horizontal motion unit (x) is used.

When the starting position is set to the upper right or lower left of the printable area using ESC T, the vertical motion unit (y) is used.

[Reference] **ESC \$, ESC P**

## **ESC a n**

[Name] Select justification

[Format] ASCII ESC a n

HEX 1B 61 n

Decimal 27 97 n

[Range]  $0 \leq n \leq 2$

$48 \leq n \leq 50$

[Description] Aligns all the data in one line to the specified position. n selects the type of justification as follows;

n	Justification
0, 48	Left justification
1, 49	Center justification
2, 50	Right justification

- [Notes]
- 1) The command is enabled only when processed at the beginning of the line in standard mode.
  - 2) If this command is input in page mode, the printer performs only internal flag operations.
  - 3) This command has no effect in page mode.
  - 4) This command executes justification in the printing area.
  - 5) This command justifies the space area according to HT, ESC \$ or ESC \
- [Default] n = 0

[Example]

Left justification	Center justification	Right justification
<pre> ABC ABCD ABCDE </pre>	<pre>       ABC      ABCD     ABCDE </pre>	<pre>                 ABC                ABCD               ABCDE </pre>

## **HT**

- [Name] Horizontal Tab
- [Format] ASCII HT  
 HEX 09  
 Decimal 9
- [Description] Moves the print position to the next horizontal tab position.
- [Note]
- 1) This command is ignored unless the next horizontal tab position has been set.
  - 2) If the next horizontal tab position exceeds the printing area, the printer sets the printing position to [Printing area width + 1]
  - 3) Horizontal tab positions are set with ESC D.
  - 4) If this command is received when the printing position is at [Printing area width + 1], the printer executes print buffer-full printing of the current line and horizontal tab processing from the beginning of the next line.
  - 5) The default setting of the horizontal tab position for the paper roll is every 0<sup>th</sup> character.
- [Reference] **ESC D**

## ESC D n1...nk NUL

[Name]	Set horizontal tab positions.
[Format]	ASCII    ESC    D        n1...nk    NUL HEX    1B    44        n1...nk    00 Decimal 27        68        n1...nk    0
[Range]	$1 \leq n \leq 255$ $0 \leq k \leq 32$
[Description]	Set horizontal tab position
[Notes]	<ol style="list-style-type: none"><li>1) n specifies the column number for setting a horizontal tab position from the beginning of the line.</li><li>2) k indicates the total number of horizontal tab positions to be set.</li><li>3) The horizontal tab position is stored as a value of [character width * n] measured from the beginning of the line. The character width includes the right-side character spacing, and double-width characters are set with twice the width of normal characters.</li><li>4) This command cancels the previous horizontal tab settings.</li><li>5) When setting n=8, the print position is moved to column 9 by sending HT.</li><li>6) Up to 32 tab positions (k=32) can be set. Data exceeding 32 tab positions is processed as normal data.</li><li>7) Transmit [n]k in ascending order and place a NUL code 0 at the end.</li><li>8) When [n]k is less than or equal to the preceding value [n]k-1, tab setting is finished and the following data is processed as normal data.</li><li>9) ESC D NUL cancels all horizontal tab positions.</li><li>10) The previously specified horizontal tab positions do not change, even if the character width changes.</li><li>11) The character width is memorized for each standard and page mode.</li></ol>
[Default]	The default tab positions are at intervals of 0 characters.
[Reference]	<b>HT</b>

## GS L nL nH

[Name]	Set left margin.				
[Format]	ASCII	GS	L	nL	nH
	HEX	1D	4C	nL	nH
	Decimal	29	76	nL	nH
[Range]	$0 \leq nL \leq 255, 0 \leq nH \leq 255$				
[Description]	Set the left margin using nL and nH.				
[Notes]1)	The left margin is set to $[(nL + nH * 256)] * (\text{horizontal motion unit})$ inches.				

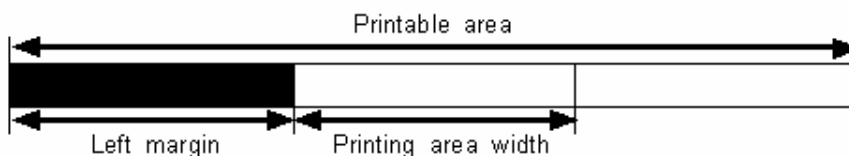

- 2) This command is effective only processed at the beginning of the line in standard mode.
  - 3) If this command is input in page mode, the printer performs only internal flag operations.
  - 4) This command does not affect printing in page mode.
  - 5) If the setting exceeds the printable area, the maximum value of the printable area is used.
  - 6) The horizontal and vertical motion units are specified by GS P.
- Changing the horizontal and vertical motion unit does not affect the current left margin.
- 7) The horizontal motion unit (x) is used for calculating the left margin.
- The calculated result is truncated to the minimum value of the mechanical pitch.

[Default]	nL = 0, nH = 0
[Reference]	GS P, GS W

## GS W nL nH

[Name] Set printing area width

[Format] ASCII GS W nL nH  
HEX 1D 57 nL nH  
Decimal 29 87 nL nH

[Range]  $0 \leq nL \leq 255, 0 \leq nH \leq 255$

[Description] Sets the printing area width to the area specified by nL and nH.

[Notes] 1) The printing area width is set to  $[(nL+nH *256)] * \text{horizontal motion unit inches}$ .

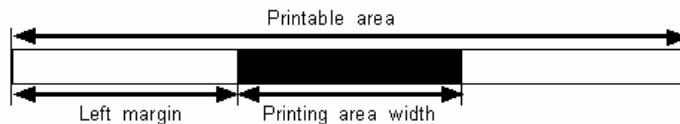

2) This command is effective only processed at the beginning of the line.

3) In page mode, the printer performs only internal flag operations.

4) This command does not affect printing in page mode.

5) If the [left margin + printing area width] exceeds the printable area, (printable area width - left margin) is used.

6) The horizontal and vertical motion units are specified by GS P.

Changing the horizontal and vertical motion units does not affect the current left margin.

7) The horizontal motion unit (x) is used for calculating the printing area width.

The calculated result is truncated to the minimum value of the mechanical pitch.

8) If the width set for the printing area is less than the width of one character, when the character data is developed, the following

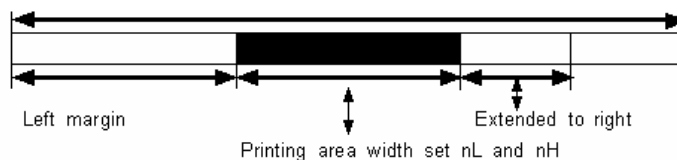

If the printing area width cannot be extended sufficiently, the left margin is reduced to accommodate one character.

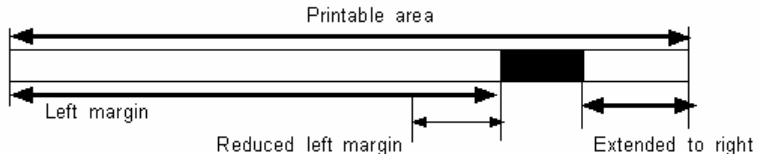

If the printing area width cannot be extended sufficiently, the right space is reduced.

9) If the width set for the printing area is less than one line in vertical, the following processing is performed only on the line in question when data other than character data(e.g., bit image, user defined bit image) is developed:

The printing area width is extended to the right to accommodate one line in vertical for the bit image within the printable area. If the printing area width cannot be extended sufficiently, the left margin is reduced to accommodate one line in vertical.

[Default] nL = 0, nH = 2

[Reference] **GS L, GS P**

### **ESC W xL xH yL yH dxL dxH dyL dyH**

[Name] Set printing area in page mode

[Format] ASCII ESC W xL xH yL yH dxL dxH dyL dyH  
 HEX 1B 57 xL xH yL yH dxL dxH dyL dyH  
 Decimal 27 87 xL xH yL yH dxL dxH dyL dyH

[Range]  $0 \leq xL, xH, yL, yH, dxL, dxH, dyL, dyH \leq 255$   
 (except  $dxL=dxH=0$  or  $dyL=dyH=0$ )

[Description] The horizontal starting position, vertical starting position, printing area width, and printing area height are defined as  $x0, y0, dx(\text{inch})$ , respectively.

$$x0 = [(xL + xH * 256)] * (\text{horizontal motion unit})$$

$$y0 = [(yL + yH * 256)] * (\text{vertical motion unit})$$

$dx = [(dxL + dxH * 256)] * (\text{horizontal motion unit})$

$dy = [(dyL + dyH * 256)] * (\text{vertical motion unit})$

The printing area is set as shown in the figure below.

[Note]

- 1) If this command is input in standard mode, the printer executes only internal flag operation. This command does not affect printing in standard mode.
- 2) If the horizontal or vertical starting position is set outside the printable area, the printer stops command processing and processes the following data as normal data.
- 3) If the printing area width or height is set to 0, the printer stops command processing and processes the following data as normal data.
- 4) This command sets the position where data is buffered to the position specified by ESC T within the printing area.
- 5) If (horizontal starting position + printing area width) exceeds the printable area, the printing area width is automatically set to (horizontal printable area - horizontal starting position).
- 6) If (vertical starting position + printing area height) exceeds the printable area, the printing area height is automatically set to (vertical printable area - vertical starting position).
- 7) The horizontal and vertical motion unit are specified by GS P. Changing the horizontal or vertical motion unit does not affect the current printing area.
- 8) The GS P command can change the horizontal (and vertical) motion unit. However, the value cannot be less than the minimum horizontal movement amount, and it must be in even units of minimum horizontal movement amount.
- 9) Use the horizontal motion unit (x) for setting the horizontal starting position and printing area width, and use the vertical motion unit (y) for setting the vertical starting position and printing area height.
- 10) When the horizontal starting position, vertical starting position, printing area width, and printing area height are defined as X, Y, Dx, Dy respectively, the printing area is set as shown in the figure below.

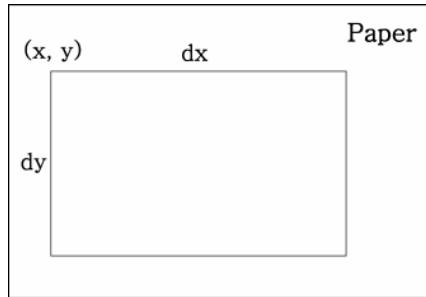

[Default]  $xL = xH = yL = yH = 0$   
 $dxL = 0, dxH = 2, dyL = 126, dyH = 6$

[Reference] **CAN, ESC L, ESC T, GS P**

### **ESC T n**

[Name] Select print direction in page mode

[Format] ASCII ESC T n  
 HEX 1B 54 n  
 Decimal 27 84 n

[Range]  $0 \leq n \leq 3$  or  $48 \leq n \leq 51$

[Description] Selects the print direction and starting position in page mode.  
 n specifies the print direction and starting position as follows;

n	Print direction	Starting position
0,48	Left to right	Upper left (A in the figure)
1,49	Bottom to top	Lower left (B in the figure)
2,50	Right to left	Lower right (C in the figure)
3,51	Top to bottom	Upper right (D in the figure)



[Notes]	<p>1) When the command is input in standard mode, the printer executes only internal flag operation. This command does not affect printing in standard mode.</p> <p>2) This command sets the position where data is buffered within the printing area set by ESC W.</p> <p>3) Parameters for horizontal or vertical motion units (X or Y) differ as follows, depending on the starting position of the printing area;</p> <p>If the starting position is the upper left or lower right of the printing area, data is buffered in the direction perpendicular to the paper feed direction.</p> <p>Commands using horizontal motion unit: ESC SP, ESC \$, ESC \</p> <p>Commands using vertical motion unit: ESC 3, ESC J, GS \$, GS \</p> <p>If the starting position is the upper right or lower left of the printing area, data is buffered in the paper feed direction.</p> <p>Commands using horizontal motion units : ESC 3, ESC J, GS \$, GS \</p> <p>Commands using vertical motion units : ESC SP, ESC \$, ESC \</p>
[Default]	n = 0
[Reference]	<b>ESC \$, ESC L, ESC W, ESC \, GS \$, GS P, GS \</b>

### **GS \$ nL nH**

[Name]	Set absolute vertical print position in page mode.															
[Format]	<table border="0"> <tr> <td>ASCII</td> <td>GS</td> <td>\$</td> <td>nL</td> <td>nH</td> </tr> <tr> <td>HEX</td> <td>1D</td> <td>24</td> <td>nL</td> <td>nH</td> </tr> <tr> <td>Decimal</td> <td>29</td> <td>36</td> <td>nL</td> <td>nH</td> </tr> </table>	ASCII	GS	\$	nL	nH	HEX	1D	24	nL	nH	Decimal	29	36	nL	nH
ASCII	GS	\$	nL	nH												
HEX	1D	24	nL	nH												
Decimal	29	36	nL	nH												
[Range]	$0 \leq nL \leq 255, 0 \leq nH \leq 255$															
[Description]	Sets the absolute vertical print starting position for buffer character data in page mode.															
[Notes]	<p>1) This command sets the absolute print position to <math>[(nL+nH * 256)] * (\text{vertical or horizontal motion unit})</math> inches.</p> <p>2) This command is effective only in page mode.</p> <p>3) If the <math>[(nL + nH * 256)] * (\text{vertical or horizontal motion unit})</math> exceeds the specified printing area, this command is ignored.</p> <p>4) The horizontal starting buffer position does not move.</p>															

- 5) The reference starting position is that specified by ESC T.
- 6) This command operates as follows, depending on the starting position of the printing area specified by ESC T; When the starting position is set to the upper left or lower right, this command sets the absolute position in the vertical direction. When the starting position is set to the upper right or lower left, this command sets the absolute position in the horizontal direction.
- 7) The horizontal and vertical motion unit are specified by GS P.
- 8) The GS P command can change the horizontal and vertical motion unit. However, the value cannot be less than the minimum horizontal movement amount, and it must be in even units of the minimum horizontal movement amount.

[Reference] **ESC \$, ESC T, ESC W, ESC \, GS P, GS \**

### **GS \ nL nH**

[Name]	Set relative vertical print position in page mode				
[Format]	ASCII	GS	\	nL	nH
	HEX	1D	5C	nL	nH
	Decimal	29	92	nL	nH
[Range]	0 ≤ nL ≤ 255				
	0 ≤ nH ≤ 255				
[Description]	Sets the relative vertical print starting position from the current position in page mode.				
[Notes]	<p>1) This command sets the distance from the current position to [(nL + nH * 256)] * vertical or horizontal motion unit inches.</p> <p>2) This command is ignored unless page mode is selected.</p> <p>3) When pitch N is specified to the movement downward;</p> $nL + nH * 256 = N$ <p>When pitch N is specified to the movement upward (the negative direction), use the complement of 65536.</p> <p>When pitch N is specified to the movement upward;</p> $nL + nH * 256 = 65536 - N$				

4) Any setting that exceeds the specified printing area is ignored.

5) This command function as follows, depending on the print starting position set by ESC T;

When the starting position is set to the upper left or lower right of the printing, the vertical motion unit (y) is used.

When the starting position is set to the upper right or lower left of the printing, the horizontal motion unit (x) is used.

6) The horizontal and vertical motion unit are specified by GS P.

7) The GS P command can change the horizontal (and vertical) motion unit. However, the value cannot be less than the minimum horizontal movement amount, and it must be in even units of the minimum horizontal movement amount.

[Reference] **ESC \$, ESC T, ESC W, ESC \, GS \$, GS P**

### **ESC O xL xH yL yH**

[Name] Set print starting position.

[Format]	ASCII	ESC	O	xL	xH	yL	yH
	HEX	1B	4F	xL	xH	yL	yH
	Decimal	27	79	xL	xH	yL	yH

[Description] Set horizontal starting position and vertical starting position in page mode.

Horizontal starting position =  $xL + xH * 256$

Vertical starting position =  $yL + yH * 256$

[Note] This command is effective only in page mode.

## 7.6. Bit-Image Commands.

The WSP-i350 supports the following bit-image command.

Command	Name
ESC *	Select bit image mode
ESC X 4	Define user-defined bit image

### ESC \* m nL nH d1 dk

[Name] Select bit-image mode.

[Format] ASCII ESC \* m nL nH d1...dk  
 HEX 1B 2A m nL nH d1...dk  
 Decimal 27 42 m nL nH d1...dk

[Range] m = 0,1,32,33  
 $0 \leq nL \leq 255$   
 $0 \leq nH \leq 3$   
 $0 \leq d \leq 255$

[Description] Selects a bit-image mode using m for the number of dots specified by nL and nH, as follows:

m	mode	Vertical direction		Horizontal direction	
		Number of Dots	Dot density	Dot density	Number of Data
0	8 dot single density	8	68 DPI	102 DPI	$nL+nH*256$
1	8 dot double density	8	68 DPI	203 DPI	$nL+nH*256$
32	24 dot single density	24	203DPI	102 DPI	$(nL+nH*256)*3$
33	24 dot double density	24	203 DPI	203 DPI	$(nL+nH*256)*3$

[Notes]

- 1) If the values of m is out of the specified range, nL and data following are processed an normal data.
- 2) The nL and nH indicate the number of dots of the bit image in the horizontal direction.
- 3) The number of dots is calculated by  $nL + nH * 256$ .
- 4) If the bit-image data input exceeds the number of dots to be printed on a line, the excess data is ignored.
- 5) d indicates the bit-image data. Set a corresponding bit to 1 to print a dot or to 0 to not print a dot.
- 6) If the width of the printing area set by GS L and GS W less than the width required by the data sent with the ESC \* command, the following will be performed on the line in question (but the printing cannot exceed the maximum printable area):  
The width of the printing area is extended to the right to accommodate the amount of data.  
If step does not provide sufficient width for the data, the left margin is reduced to accommodate the data.
- 7) After printing a bit image, the printer returns to normal data processing mode.
- 8) This command is not affected by print modes (emphasized, double-strike, underline, character size or White/Black reverse printing), except upside-down printing mode.
- 9) The relationship between the image data and the dots to be printed is as follows;

- When 8-dot bit image is selected

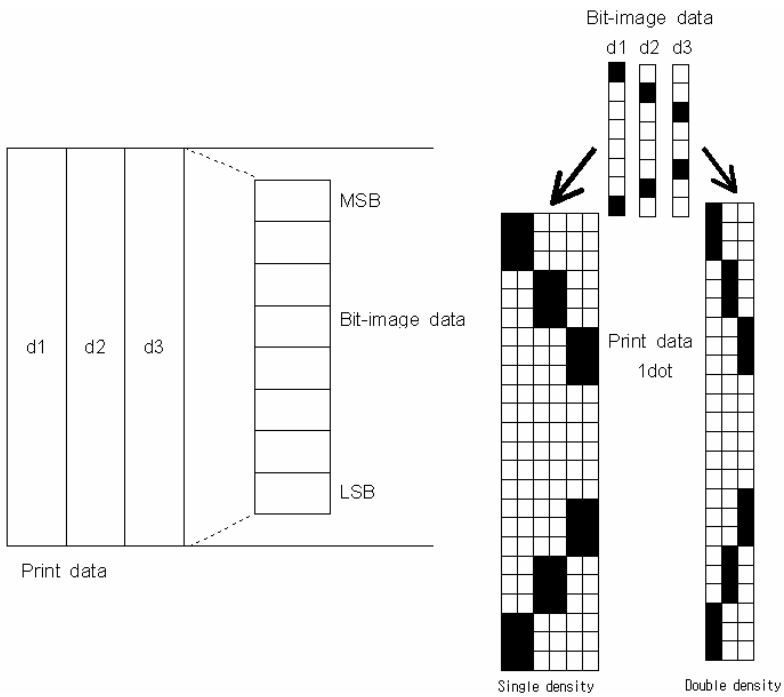

- When 24-dot bit image is selected

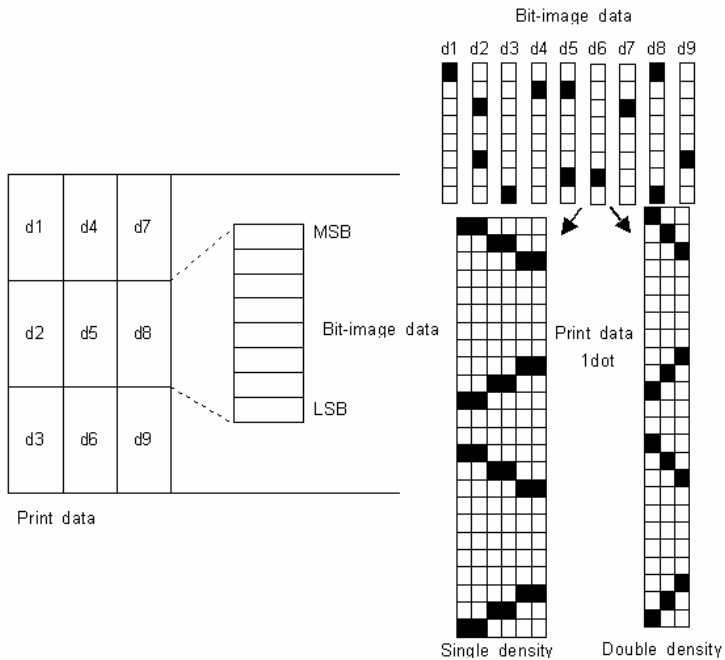

**ESC X 4 x y d1...dk**

[Name] Define user-defined bit-image

[Format] ASCII ESC X 4 x y d1...dk  
 HEX 1B 58 34 x y d1...dk  
 Decimal 27 88 52 x y d1...dk

[Description] **ESC X 4 x y d1 ... d(x .y)** defines a user-defined bit image using **x**.  
 8 dots in the horizontal direction and **y** dots in the vertical direction.  
 - Horizontal direction dots = (x \* 8)dots  
 - Vertical direction dots = (y)dots

x =2, y= 20

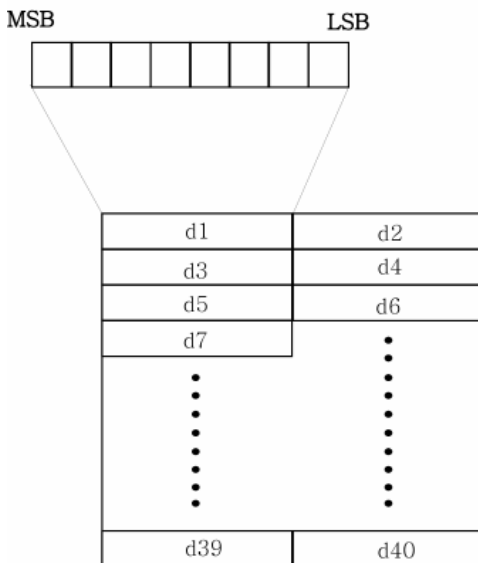

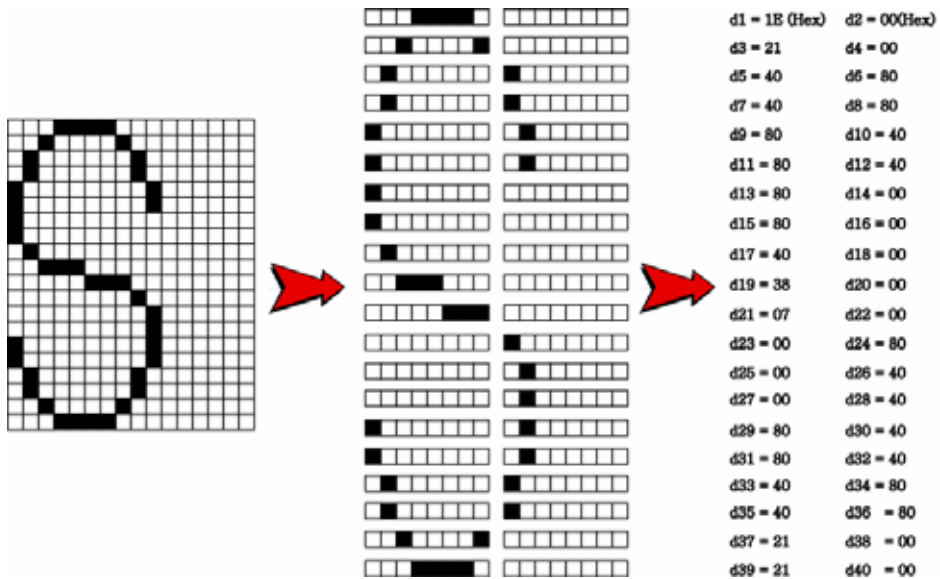

[Reference] ESC W, ESC O, FF

## 7.7. Status Commands.

The WSP- i350 supports the following status transmission command.

Command	Name
ESC v	Transmit paper sensor status

### ESC v

[Name] Transmit paper sensor status

[Format] ASCII ESC v  
 HEX 1B 76  
 Decimal 27 118

[Description] ESC v transmits the status of a paper sensor as 1byte of data.

When the paper roll end sensor detects a paper, printer transmits the 0(H30) data.

When the paper roll end sensor doesn't detect a paper, printer don't Transmit the 1(H31) data.

## 7.8. Barcode Commands.

The **WSP-i350** supports the following barcode commands.

<b>Command</b>	<b>Name</b>
<b>GS h</b>	Set barcode height
<b>GS w</b>	Set barcode width
<b>GS k</b>	Print bar code
<b>GS H</b>	Select printing position of Human Readable Interpretation (HRI) characters

### **GS h n**

[Name]	Set barcode height
[Format]	ASCII GS h n HEX 1D 68 n Decimal 29 104 n
[Range]	$0 \leq n \leq 255$
[Description]	<b>GS h n</b> selects the height of a barcode. <b>n</b> specifies the number of dots in the vertical direction. One dot corresponds 1/8mm. The default setting is $n = 80$ .

### **GS w n**

[Name]	Set barcode width
[Format]	ASCII GS w n HEX 1D 77 n Decimal 29 119 n
[Range]	$n = 0, 3 \leq n \leq 5$
[Description]	<b>GS w n</b> selects the horizontal size of a barcode. The default setting is $n = 0$ .

**①GS k m d1...dk NUL      ②GS k m n d1...dn**

[Name]                      Print barcode

[Format]                    ①ASCII                    GS        k            m d1...dk NUL  
                                   HEX                    1D        6B            m d1...dk 00  
                                   Decimal                29        107          m d1...dk 0  
                                   ②ASCII                    GS        k            m n d1...dn  
                                   HEX                    1D        6B            m n d1...dn  
                                   Decimal                29        107          m n d1...dn

[Range]                    ①  $0 \leq m \leq 6$  (k and d depends on the bar code system used.)  
                                   ②  $0 \leq m \leq 6$  (n and d depends on the bar code system used.)

[Description]            **GS k m d1...dk NUL** selects a barcode system and print the barcode.  
                                   **m** specifies a bar code system as follows;

①

m	Barcode System	Number of character	Remarks
0	UPC-A	$11 \leq k \leq 12$	$48 \leq d \leq 57$
1	UPC-E	$11 \leq k \leq 12$	$48 \leq d \leq 57$
2	EAN13	$11 \leq k \leq 13$	$48 \leq d \leq 57$
3	EAN8	$7 \leq k \leq 8$	$48 \leq d \leq 57$
4	CODE39	$1 \leq k$	$48 \leq d \leq 57, 65 \leq d \leq 90,$ $d = 32, 36, 37, 43, 45, 46, 47$
5	ITF	$1 \leq k$ (even number)	$48 \leq d \leq 57$
6	CODABAR	$1 \leq k$	$48 \leq d \leq 57, 65 \leq d \leq 68,$ $d = 36, 43, 45, 46, 47, 58$

②

m	Barcode System	Number of characters	Remarks
65	UPC-A	$11 \leq n \leq 12$	$48 \leq d \leq 57$
66	UPC-E	$11 \leq n \leq 12$	$48 \leq d \leq 57$
67	EAN13	$11 \leq n \leq 13$	$48 \leq d \leq 57$
68	EAN8	$7 \leq n \leq 8$	$48 \leq d \leq 57$
69	CODE39	$1 \leq n \leq 255$	$48 \leq d \leq 57, 65 \leq d \leq 90,$ $d = 32, 36, 37, 43, 45, 46, 47$
70	ITF	$1 \leq n \leq 255$ (even number)	$48 \leq d \leq 57$
71	CODABAR	$1 \leq n \leq 255$	$48 \leq d \leq 57, 65 \leq d \leq 68,$ $d = 36, 43, 45, 46, 47, 58$
72	CODE93	$1 \leq n \leq 255$	$0 \leq d \leq 127$
73	EAN128	$2 \leq n \leq 255$	$0 \leq d \leq 127$ $d=C1H$ (FNC1) $d=C2H$ (FNC2) $d=C3H$ (FNC3) $d=C4H$ (FNC4)

[Notes]

- 1) This command ends with a NUL code.
- 2) When the bar code system used is UPC-A or UPC-E, the printer prints the bar code data after receiving 12 bytes bar code data and processes the following data as normal data.
- 3) When the bar code system used in EAN13, the printer prints the bar code after receiving 13 bytes bar code data and processes the following data as normal data.
- 4) When the bar code system used in EAN8, the printer prints the bar code after receiving 8 bytes bar code data and processes following data as normal data.
- 5) The number of data for ITF bar code must be even numbers.  
When an odd number of data is input, the printer ignores the last received data.

- 6) EAN128 Barcode must insert FNC1 in first data.
- 7) n indicates the number of bar code data, and the printer processes n bytes from the next character data as bar code data.
- 8) If n is outside of the specified range, the printer stops command processing and processes the following data as normal data.
- 9) Be sure to keep spaces on both right and left sides of a bar code.  
Spaces are different depending on the types of the bar code.

[Reference] **GS h, GS w, GS H, ESC L, ESC W, ESC FF**

### **GS H n**

[Name] Turn HRI characters print mode ON/OFF

[Format]	ASCII	GS	H	n
	HEX	1D	48	n
	Decimal	29	72	n

[Range] n = 0, 1

[Description] **GS H n** turns HRI characters print mode on or off.  
When the LSB(least significant bit) of **n** is 1,  
HRI characters print mode is turned on;  
When it is 0, HRI character print mode is turned off.  
The default setting is n=0.

### ESC Z m n k d d1...dn

[Name]	Print 2D barcode
[Format]	ASCII    ESC    Z            m   n   k   d   d1...dn HEX    1B    5A            m   n   k   d   d1...dn Decimal 27    90            m   n   k   d   d1...dn
[Range]	$1 \leq m \leq 7$ $0 \leq n \leq 8$ $2 \leq k \leq 5$ $1 \leq d \leq 65535$
[Description]	Print 2D bar code (PDF417 format). <i>m</i> specifies column number of 2D bar code. <i>n</i> specifies security level to restore when bar code image is damaged. <i>k</i> is used for define horizontal and vertical ratio. <i>d</i> is consist of 2 byte. 1st byte is lower number. And 2nd byte is upper number.

**\* M16C , ARM Version only.**

### GS Z n

[Name]	Select 2D barcode type
[Format]	ASCII    GS    Z            n HEX    1D    5A            n Decimal 27    90            n
[Range]	n=0 : PDF417(default) n=1 : DATAMATRIX n=2 : QR-CODE

## **ESC Z m n k d d1...dn**

[Name]	Print 2D barcode						
[Format]	ASCII	ESC	Z	m	n	k	d d1...dn
	HEX	1B	5A	m	n	k	d d1...dn
	Decimal	27	90	m	n	k	d d1...dn

### [Description]

#### DATAMATRIX Type:

*m* specifies height of the symbol. (0:auto size)

*n* specifies width of the symbol. (if m=0, don't care)

*k* specifies module size. (1~8)

*d* is consist of 2 byte. 1st byte is lower number.

And 2nd byte is upper number.

#### QR-CODE Type:

*m* specifies version of the symbol. (1~40, 0:auto size)

*n* specifies ECC level. (L:7%, M:15%,Q:25%,H:30%)

*k* specifies module size. (1~8)

*d* is consist of 2 byte. 1st byte is lower number.

And 2nd byte is upper number.

## 7.9. Macro Function Commands.

The WSP-i350 supports the following macro function commands;

<b>Command</b>	<b>Name</b>
<b>GS :</b>	Start/end macro definition
<b>GS ^</b>	Execute macro

### **GS :**

[Name] Start/End macro definition

[Format] ASCII GS :  
HEX 1D 3A  
Decimal 29 58

[Description] Starts ends macro definition.

[Notes]

- 1) Macro definition starts when this command is received during normal operation. Macro definition ends when this command is received during macro definition.
- 2) When GS ^ is received during macro definition, the printer ends macro definition and clears the definition.
- 3) Macro is not defined when the power is turned on.
- 4) The defined contents of the macro are not cleared by ESC @. Therefore, ESC @ can be included in the contents of the macro definition.
- 5) If the printer receives GS : again immediately after previously receiving GS : the printer remains in the macro undefined state.
- 6) The contents of the macro can be defined up to 2048 bytes. If the macro definition exceed 2048 bytes, excess data is not stored.

[Reference] GS ^

## GS ^ r t m

[Name]	Execute macro.
[Format]	ASCII GS ^ r t m HEX 1D 5E r t m Decimal 29 94 r t m
[Range]	$0 \leq r \leq 255$ $0 \leq t \leq 255$ $m = 0, 1$
[Description]	Executes a macro.
[Notes]	1) r specifies the number of times to execute the macro. 2) t specifies the waiting time for executing the macro. <b>※ t function is not available now.</b> 3) m specifies macro executing mode. When LSB of m = 0 The macro executes r times continuously at the interval specified by t. When LSB of m = 1 After waiting for the period specified by t, the ERROR LED indicators blink and the printer waits for the FEED button to be pressed. After the button is pressed, the printer executes the macro once. The printer repeats the operation r times. 4) The waiting time is $t \times 100$ ms for every macro execution. 5) If this command is received while a macro is being defined, the macro definition is aborted and the definition is cleared. 6) If the macro is not defined or if is 0, nothing is executed. 7) When the macro is executed (m=1), paper always cannot be fed by using the FEED button.
[Reference]	GS :

## 7.10. Miscellaneous function commands.

The **WSP-i350** supports the following miscellaneous function commands;

<b>Command</b>	<b>Name</b>
<b>ESC @</b>	Initialize printer
<b>ESC L</b>	Select page mode
<b>ESC S</b>	Select standard mode
<b>CAN</b>	Cancel print data in page mode

### **ESC @**

[Name]	Initialize printer.
[Format]	ASCII   ESC    @ HEX     1B    40 Decimal 27    64
[Description]	Clears the data in the print buffer and resets the printer mode to the mode that was in effect when the power was turned on.
[Notes]	1) The data in the receive buffer is not cleared. 2) The macro definition is not cleared.

### **ESC L**

[Name]	Select page mode
[Format]	ASCII   ESC    L HEX     1B    4C Decimal 27    76
[Description]	Switches from standard mode to page mode.
[Notes]	1) This command is enabled only when processed at the beginning of a line in standard mode. 2) This command has no effect in page mode. 3) After printing by FF is completed or by using ESC S, the printer returns to standard mode.

4) This command sets the position where data is buffered to the position specified by ESC T within the printing area defined by ESC W.

5) This command switches the settings for the following commands (in which the values can be set independently in standard mode and page mode) to those for page mode;

Set right-side character spacing : ESC SP

Select default line spacing : ESC 2, ESC 3

6) Only valve settings is possible for the following commands in page mode; these commands are not executed.

Select justification : ESC a

Turn upside-down printing mode on/off : ESC {

Set left margin : GS L

Set printable area width : GS W

7) The printer returns to standard mode when power is turned on, the printer is reset, or ESC @ is used.

[Reference]

**FF, CAN, ESC FF, ESC S, ESC T, ESC W, GS \$, GS \**

## **ESC S**

[Name] Select standard mode

[Format] ASCII ESC S

HEX 1B 53

Decimal 27 83

[Description] Switches from page mode to standard mode.

[Note]

1) This command is effective only in page mode.

2) Data buffered in page mode are cleared.

3) This command sets the print position to the beginning of the line.

4) The printing area set by ESC W are initialized.

5) This command switches the settings for the following commands (in which the values can be set independently in standard mode and page mode) to those for standard mode;

Set right-side character spacing : ESC SP

Select default line spacing : ESC 2, ESC 3

6) The following commands are enabled only to set in standard mode.

Set printing area in page mode : ESC W

Select print direction in page mode : ESC T

7) The following commands are ignored in standard mode.

Set absolute vertical print position in page mode : GS \$

Set relative vertical print position in page mode : GS \

8) Standard mode is selected automatically when power is turned on, the printer is reset, or command ESC @ is used.

[Reference] **FF, ESC FF, ESC L**

## **CAN**

[Name] Cancel print data in page mode

[Format] ASCII CAN

HEX 18

Decimal 24

[Description] In page mode, deletes all the print in the current printable area.

[Notes] This command is enable only in page mode.

If data that existed in the previously specified printing area also exists in  
The currently specified printing area, it is deleted.

[Reference] **ESC L, ESC W**

## 7.11. Line & box commands.

The WSP-i350 supports the following line & box commands;

Command	Name
GS i	Print line & box in page mode

### GS i

[Name]	Print line & box in page mode
[Format]	ASCII GS i xL xH yL yH n HEX 1D 69 xL xH yL yH n Decimal 29 105 xL xH yL yH n
[Description]	Print line & box in page mode Horizontal length : xL + xH *256(dot) Vertical length : yL+ yH*256(dot) Line thickness : n (dot) If the horizontal length is 0, it becomes vertical line If the vertical length is 0, it becomes horizontal line
[Range]	$0 \leq xL, xH, yL, yH \leq 255$ $0 \leq n \leq 255$

## 7.12. Black mark detection commands.

### **ESC P yL yH**

[Name]	Set the movement position from the black mark.				
[Format]	ASCII	ESC	P	yL	yH
	HEX	1B	50		
	Decimal	27	80		
[Description]	The movement position will be set when this command is sent to the printer just once.				

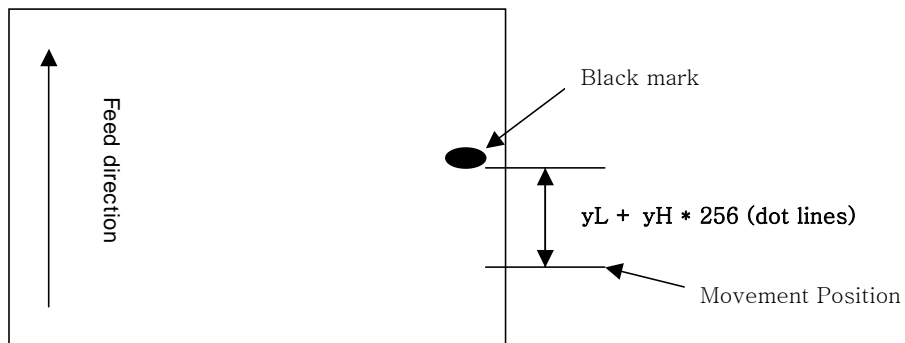

### **ESC z ESC y**

[Name]	Feed the paper to the movement position.				
[Format]	ASCII	ESC	z	ESC	y
	HEX	1B	7A	1B	79
	Decimal	27	122	27	121
[Description]	Feed the paper to the movement position.				

## 7.13. Magnetic Card Reader Commands. (optional)

The **WSP-i350** supports the following magnetic card reader commands;

<b>Command</b>	<b>Name</b>
<b>ESC M C</b>	Set 1 track (2 track) card reader mode.
<b>ESC M D</b>	Set 2 track (3 track) card reader mode.
<b>ESC M E</b>	Set 1,2 track (2,3 track ) card reader mode.
<b>EOT</b>	Cancel card reader mode

### **ESC M C**

[Name] Set 1 track (2 track) card reader mode.

[Format]

ASCII	ESC	M	C
HEX	1B	4D	43
Decimal	27	77	67

[Note] When the **ESC M C** command is executed, printed nothing before read the card or executed the **EOT** command.

### **ESC M D**

[Name] Set 2 track (3 track) card reader mode.

[Format]

ASCII	ESC	M	D
HEX	1B	4D	44
Decimal	27	77	68

[Note] When the **ESC M D** command is executed, printed nothing before read the card or executed the **EOT** command.

### **ESC M E**

[Name] Set 1,2track (2,3track) card reader mode.

[Format]

ASCII	ESC	M	E
HEX	1B	4D	45
Decimal	27	77	69

[Note] When the **ESC M E** command is executed, printed nothing before read the card or executed the **EOT** command.

## **EOT**

[Name]	Cancel card reader mode.
[Format]	ASCII    EOT HEX      04 Decimal  4
[Description]	Cancel card reader mode.

### ※ **Card specification**

The table below summarizes the format of the data stored on each magnetic track.

	<b>ISO-1 Track (IATA)</b>
<b>Recording Density</b>	210 BPI
<b>Recording Capacity</b>	79 characters
<b>Data Format</b>	Alphanumeric
<b>Data Capacity</b>	76 characters

	<b>ISO-2 Track (ABA)</b>
<b>Recording Density</b>	75 BPI
<b>Recording Capacity</b>	40 characters
<b>Data Format</b>	Numeric
<b>Data Capacity</b>	37 characters

	<b>ISO-3 Track (MINTS)</b>
<b>Recording Density</b>	210 BPI
<b>Recording Capacity</b>	107 characters
<b>Data Format</b>	Numeric
<b>Data Capacity</b>	104 characters

※ **Magnetic Card Data Output Format**

- **Track 1**

02H 43H 31H 31H 1CH	DATA (76 Characters)	1CH 03H 0DH 0AH
---------------------	----------------------	-----------------

- **Track 2**

02H 43H 31H 31H 1CH	DATA (37 Characters)	1CH 03H 0DH 0AH
---------------------	----------------------	-----------------

- **Track 3**

02H 44H 31H 31H 1CH	DATA (104 Characters)	03H 0DH 0AH
---------------------	-----------------------	-------------

- **Track 1,2**

02H 45H 31H 31H 1CH 1CH	DATA(76)	1CH	DATA(37)	1CH 03H 0DH 0AH
-------------------------	----------	-----	----------	-----------------

- **Track 2,3**

02H 45H 31H 31H 1CH 1CH	DATA(37)	1CH	DATA(104)	1CH 03H 0DH 0AH
-------------------------	----------	-----	-----------	-----------------

## 8. Introduction of Protocol IrDA (or Bluetooth)

### 8.1. Frame Structure.

<b>SOF</b> (Start Of Frame)	<b>TOF</b> (Type Of Frame)	<b>DATA</b>	<b>EOF</b> (End Of Frame)
1 Byte	1 Byte	Variable	1 Byte

- Type of frame

<b>Type of frame</b>	<b>Value</b>	<b>DATA Field</b>
ACK	0x06	X
NACK	0x15	X
ENQ	0x05	X
PRINT Data	'D' (0x44)	O
Response of Printer Status	'S' (0x53)	O
Inquiry of Printer Status	'Q' (0x51)	X
EOT	0x04	X
ETX	0x03	X

- ❖ During transmission, if C0H, C1H, and/or 7DH are contained in data field, 7DH should be inserted before the data and the data should be XOR with 20H and sent.
- ❖ During reception, if 7DH is encountered, 7DH should be ignored and the next byte should be XOR with 20H and stored.

## 8.2. Process of Getting the Printer Status.

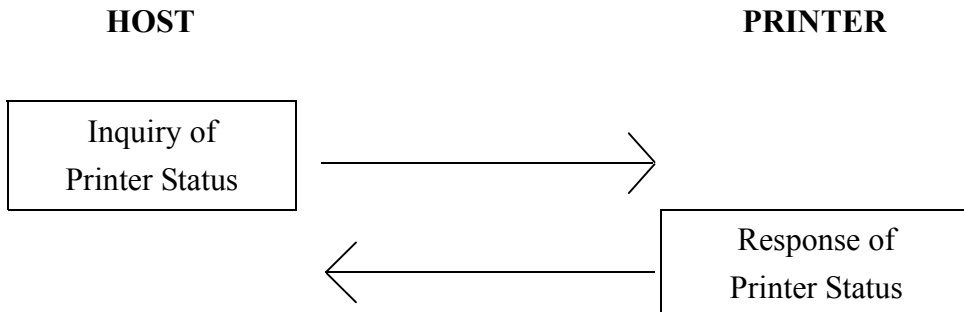

- ❖ It is recommended that the host send the same inquiry up to 5 times with 400ms time interval in case of no response from the printer.

### 8.2.1. Frame Format.

- ❖ Inquiry of printer status

0xC0	0x51	0xC1
------	------	------

- ❖ Response of printer status

0xC0	0x53	Status (1 Byte)	Previous ID # (1 Byte)	0xC1
------	------	-----------------	------------------------	------

### IMPORTANT !!

This function is not yet implemented fully. Currently the status byte is fixed to 0x02. However, this process can be used to check the communication.

### 8.3. Process of Printing Data.

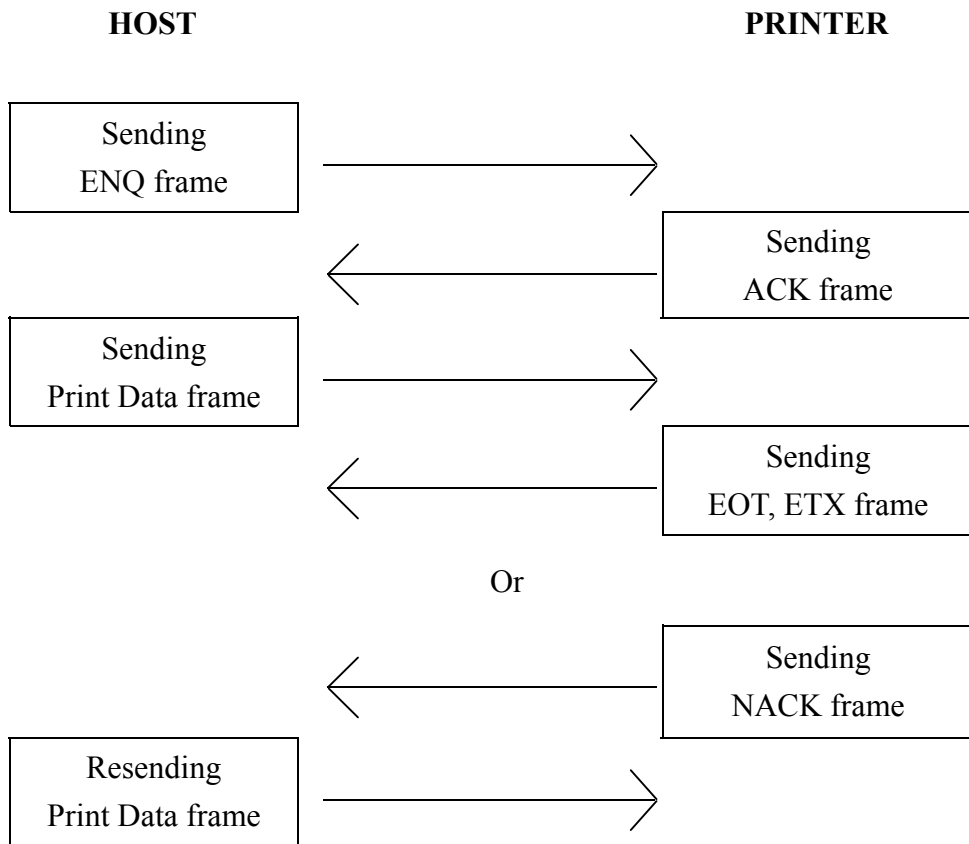

- ❖ In normal operation, after receiving the print data frame, the printer sends EOT, prints out the data, and sends ETX. And it will wait for the next frame.
  
- ❖ Conditions of NACK frame issued
  - 1) Different checksum value
  - 2) No data byte received 200ms after the previous byte received
  - 3) No EOF (End of frame) at the end
  - 4) No predefined number in Data Length field

### 8.3.1. Format of Print Data Frame.

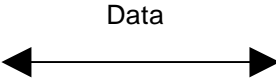
C0H	'D' (0x44)	DATA ID Number	DATA Length	Print DATA	CHECK SUM	C1H
		1 Byte	4 Bytes		2 Bytes	

- ❖ Data ID number : '0' ~ '9' (0x30~0x39). Every time the host sends a new print data frame, it increases this number.
- ❖ Data Length : "0001" ~ "9999". Each number must be an ascii code.
- ❖ Checksum : 2 bytes. The first byte is the result of XOR of even number of data in Print data field and the second byte is that of odd number.

**(Example)** If "SAMPLE TEST" is in Print Data field, the data length will be "0011 (0x30 0x30 0x31 0x31)" and the first byte of checksum will be the result of XOR of S, M, L, space, E, and T and the second byte that of A, P, E, T, and S.

- ❖ It is recommended that the host goes back to the initial stage in case that it receives neither EOT nor NACK from the printer 1 sec after it has sent the print data frame.

### 8.3.2. Format of ENQ Frame.

C0H	0x05	C1H
-----	------	-----

- ❖ It is recommended that the host send the same ENQ frame up to 10 times with 400ms time interval in case of no response from the printer.

### 8.3.3. Format of ACK Frame.

C0H	0x06	C1H
-----	------	-----

### 8.3.4. Format of NACK Frame.

C0H	0x15	C1H
-----	------	-----

### 8.3.5. Format of ETX Frame.

C0H	0x03	Data ID No.	C1H
-----	------	----------------	-----

- ❖ Printer will send this frame after it finishes all of the requested printing.

### 8.3.6. Format of EOT Frame.

C0H	0x04	C1H
-----	------	-----

- ❖ Printer will send this frame after it receives the print data frame successfully.

### ☆ IMPORTANT !!

In every frame coming from the printer, 1 Byte of Null is preceded to SOF, and CR and LF are followed by EOF.

For example, the actual data of ETX frame is 0x00, 0xC0, 0x03, 0xC1, 0x0D, and 0x0A. The host can ignore these prefix and suffixes.

# Appendix

## A. MISCELLANEOUS NOTES

### 1. Printer mechanism handling

- 1) Do not pull the paper out when the cover is closed.
- 2) Because the thermal elements of the print head and driver ICs are easy to break, so do not touch them with any metal objects.
- 3) Since the areas around the print head become very hot during and just after printing, do not touch them.
- 4) Do not use the cover open button except when necessary.
- 5) Do not touch the surface of the print head because dust and dirt can stick to the surface and damage the elements.
- 6) Thermal paper containing Na, K, Cl ions can harm the print head thermal elements.  
Therefore, be sure to use only the specified paper.
- 7) If you want to use label paper, please contact your dealer for assistance.

### 2. Thermal paper handling

- Notes on using thermal paper

Chemicals and oil on thermal paper may cause discoloration and faded printing.

Therefore, pay attention to the following;

- 1) Use water paste, starch paste, polyvinyl paste, or CMC paste when gluing thermal paper.
- 2) Volatile organic solvents such as alcohol, ester, and ketone can cause discoloration.
- 3) Some adhesive tapes may cause discoloration or faded printing.
- 4) If thermal paper touches anything which includes phthalic acid ester plasticizer for a long time, it can reduce the image formation ability of the paper and can cause the printed image to fade. Therefore, when storing thermal paper in a card case or sample notebook, be sure to use only products made from polyethylene, polypropylene, or polyester.
- 5) If thermal paper touches diazo copy paper immediately after copying, the printed surface may be discolored.
- 6) Thermal paper must not be stored with the printed surfaces against each other because the printing may be transferred between the surfaces.

7) If the surface of thermal paper is scratched with a hard metal object such as a nail, the paper may become discolored.

- Notes on thermal paper storage

Since color development begins at 70°C (158°F), thermal paper should be protected from high temperature, humidity, and light, both before and after printing.

1) Store paper away from high temperature and humidity.

Do not store thermal paper near a heater or in enclosed places exposed to direct sunlight.

2) Avoid direct light Extended exposure to direct light may cause discoloration or faded printing.

### **3. Others**

Because this printer uses plated steel, the manual cutting edge may be subject to rust.

However, this does not affect the printer performance.